

INDEX

3 * 3 * 3	122
ANNA BELLE	116
ANNETTE & LUBIN	206
BELLE D'I 20	166
BELLE D'I 38	188
BELLE D'I THE GREAT EDITION	92
DISCA	98
ESPRIT YA-YA	14
FICO	30
ICE 15 - ICE 24	78
ICE 30 - ICE A58 - ICE A78 - ICE A120	88
ICE ABSOLUT	68
ICE DEVOTION	72
ICE DONNA	84
JEWELS - NEWEL	152
LET ME READ	218
LIGHT GLOW	160
MERIDIANA	38
OND'A	200
REFLECTORS - REFLECTOR WALL - TOP REFLECTOR	106
T-COTTA	50
T-COTTA THE LAMP	58
TENSIONS	70
TENUE DE SOIREE	138
VOLTE-FACE	212
YA-YA	20



*« Love is a word of light
written by a hand of light
upon a page of light »*

Kahlil Gibran, Lebanese poet

THE
STUDIO

Sensitive and emotional manufactures.



HIND RABII IS DEVOTED TO SHEDDING LIGHT ON HIS LETTERS OF EMOTION.

Since 1997, the designers Hind Rabii and Michel Orban both industrial engineers have a common passion and love for creation, design and innovation.

We expect lights to shed light, to shine, to create shadows. To do this, the poetry of materials, glass, wood, gold and silver leaf, colours used by HIND RABII, positively alter the realities for playing the emotions card without indifference.

Because here is the poetic message of filters, colours, blended reflections, transparency that appears to make every HIND RABII model appeal to the desire of love and of light.

And today we still have, a need for these words cast on a page of white vellum.

Like you, we imagine that the HIND RABII brand is and will be synonymous with all these terms that are only language.

This language which skillfully builds itself in front of the manufactures that are glass blowing, confection of lampshades, wood, aluminum and steel work. All these trades that HIND RABII manages to show only the essentials.

As the Lebanese poet Kahlil Gibran writes, the writing of a hand of light, on a page of light is the vision of light that we offer.





« I THINK THAT THE
QUALITY OF A PRODUCT
CAN BE SUMMED UP IN 3
POINTS: THE CHOICE OF
THE MATERIAL, I ALWAYS
WORKED THE NOBLE
MATERIALS, THE DEXTERITY
OF THE HAND WHICH
TRANSFORMS IT AND THE
EYE OF THE CRAFTSMAN.
THE CRAFTSMAN WILL
ENSURE THAT THE MATERIAL
IS FINISHED IN THE MOST
BEAUTIFUL WAY. »

H.R.

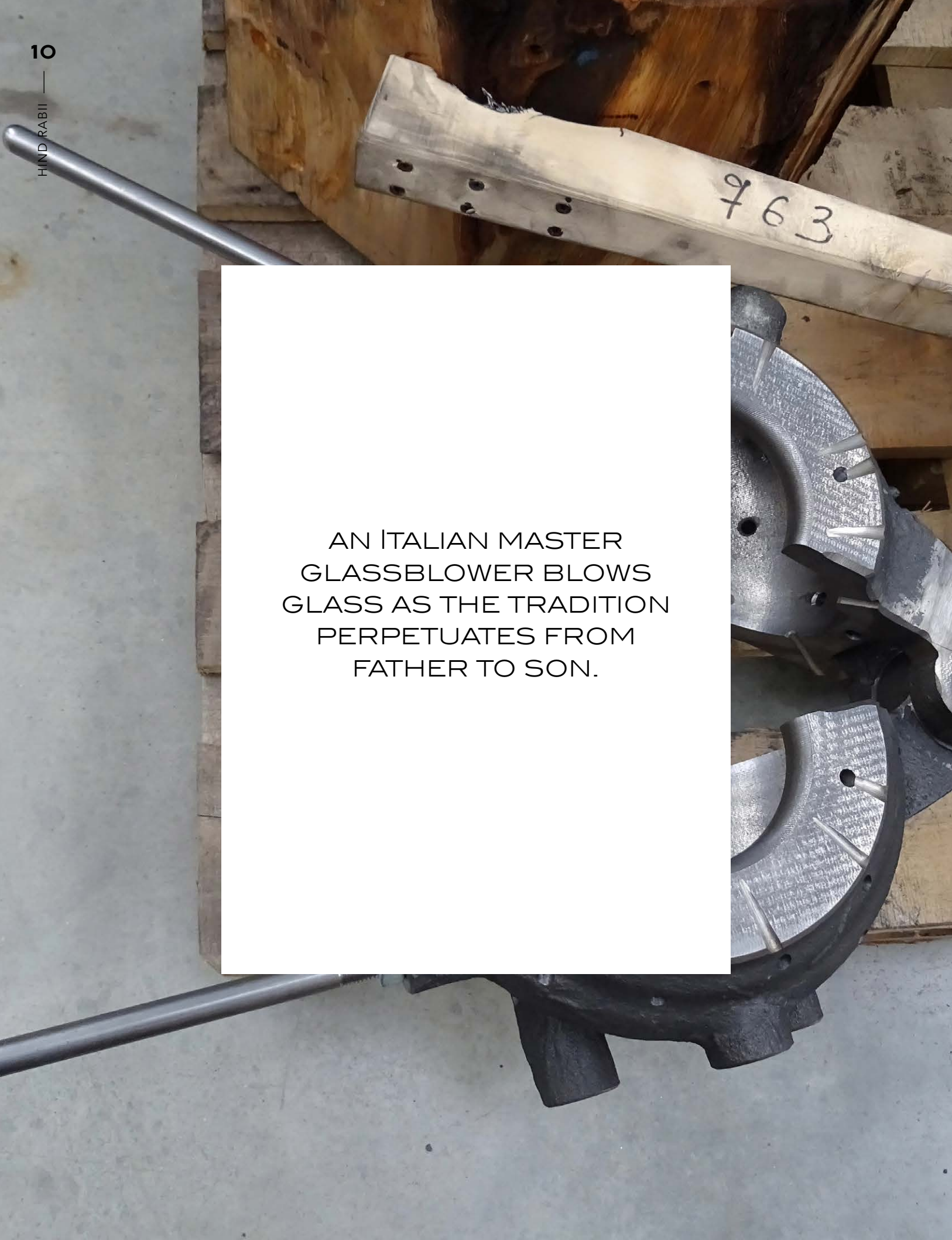

AN ITALIAN MASTER
GLASSBLOWER BLOWS
GLASS AS THE TRADITION
PERPETUATES FROM
FATHER TO SON.



THE
COLLECTIONS

The poetry of materials

ESPRIT YA-YA

Design by Hind Rabii - Maxim Pien / 2017

YA-YA is determined to be at the centre, at the heart of places, a long fresco or hooked on modest surfaces.

Its lights are all in suggestive and subtle mother-of-pearl corollas. And ESPRIT YA-YA comes loose from its surfaces to take shape in spaces. The limits of its contours double up to create magical landscapes. Through keyholes that are free and formed with sense, ESPRIT YA-YA sculpts and cuts the light to offer you what you see!

ESPRIT YA-YA feels at ease in all circumstances, dinner jackets in a 17th century Chartreuse or a Venetian palace. Esprit jeans in a plane tree. YA-YA and ESPRIT YA-YA come together harmoniously to illuminate you with their free spirits.



Esprit YA-YA gold



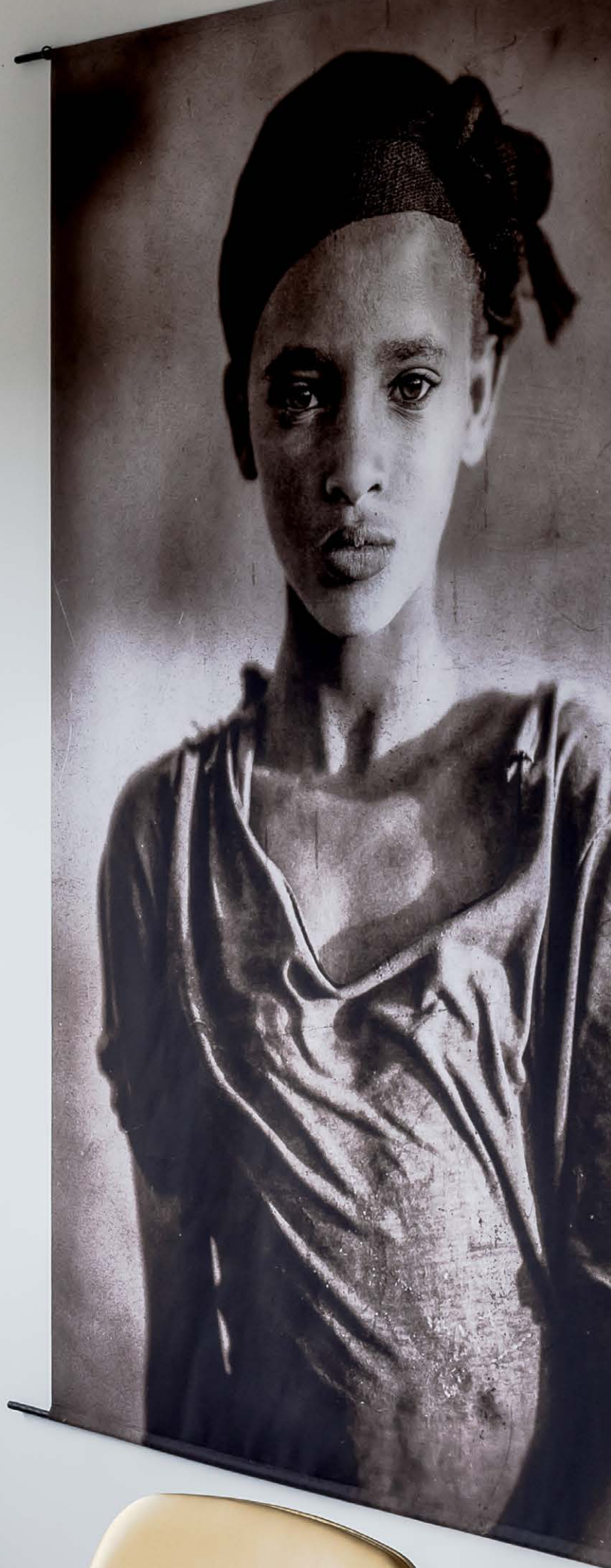

Variations and finishes of
ESPRIT YA-YA



ESP YA-YA 70



ESP YA-YA 1



ESP YA-YA 2



ESP YA-YA 3



Shiny
Gold



Black
Chrome



Matt
White

Manufacturing & technical details of **ESPRIT YA-YA**



Precision cutted metal



Hand brushed gold

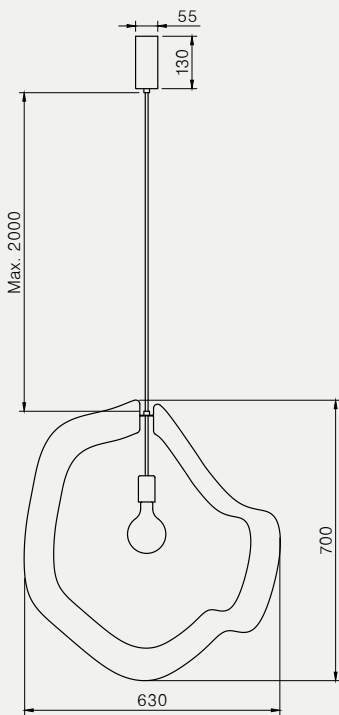

ESP YA-YA 70
E27 led bulb 6,5w 2500K 550lm

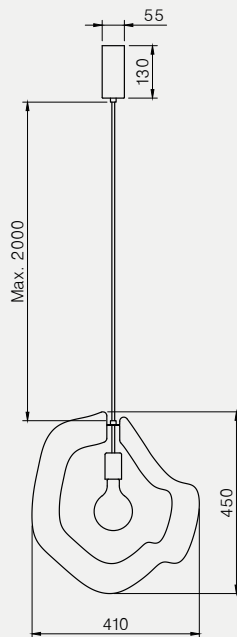

ESP YA-YA 1
E27 led bulb 5,5w 2500K 450lm

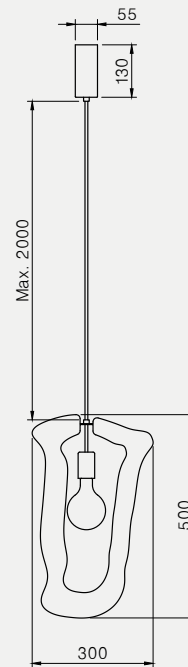

ESP YA-YA 2
E27 led bulb 6w 2500K 450lm

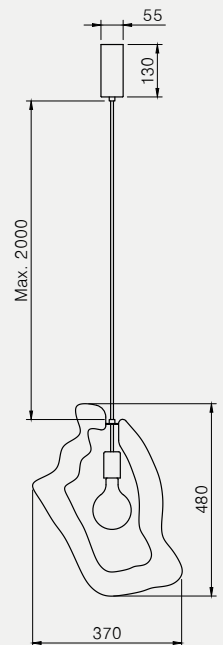

ESP YA-YA 3
E27 led bulb 6w 2500K 450lm

YA-YA

Design by Hind Rabii - Maxim Pien / 2016

YA-YA is determined to be at the centre, at the heart of places, a long fresco or hooked on modest surfaces.

Its lights are all in suggestive and subtle mother-of-pearl corollas.

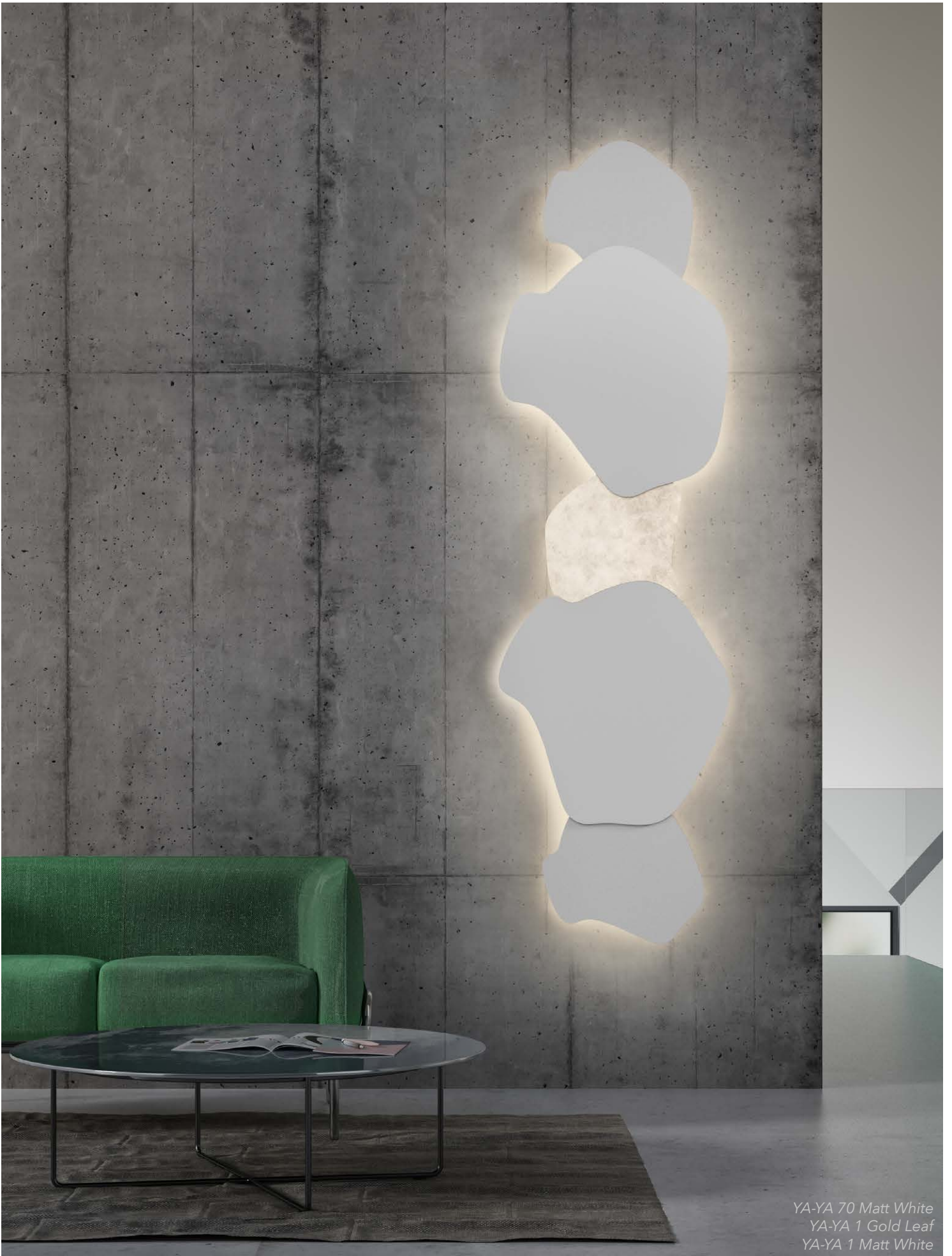

YA-YA 70 Matt White
YA-YA 1 Gold Leaf
YA-YA 1 Matt White



YA-YA 70 Gold Leaf
YA-YA 1 Matt White
YA-YA 70 Matt White

YA-YA 1 Matt White
YA-YA 70 White Marble
YA-YA 70 Matt White





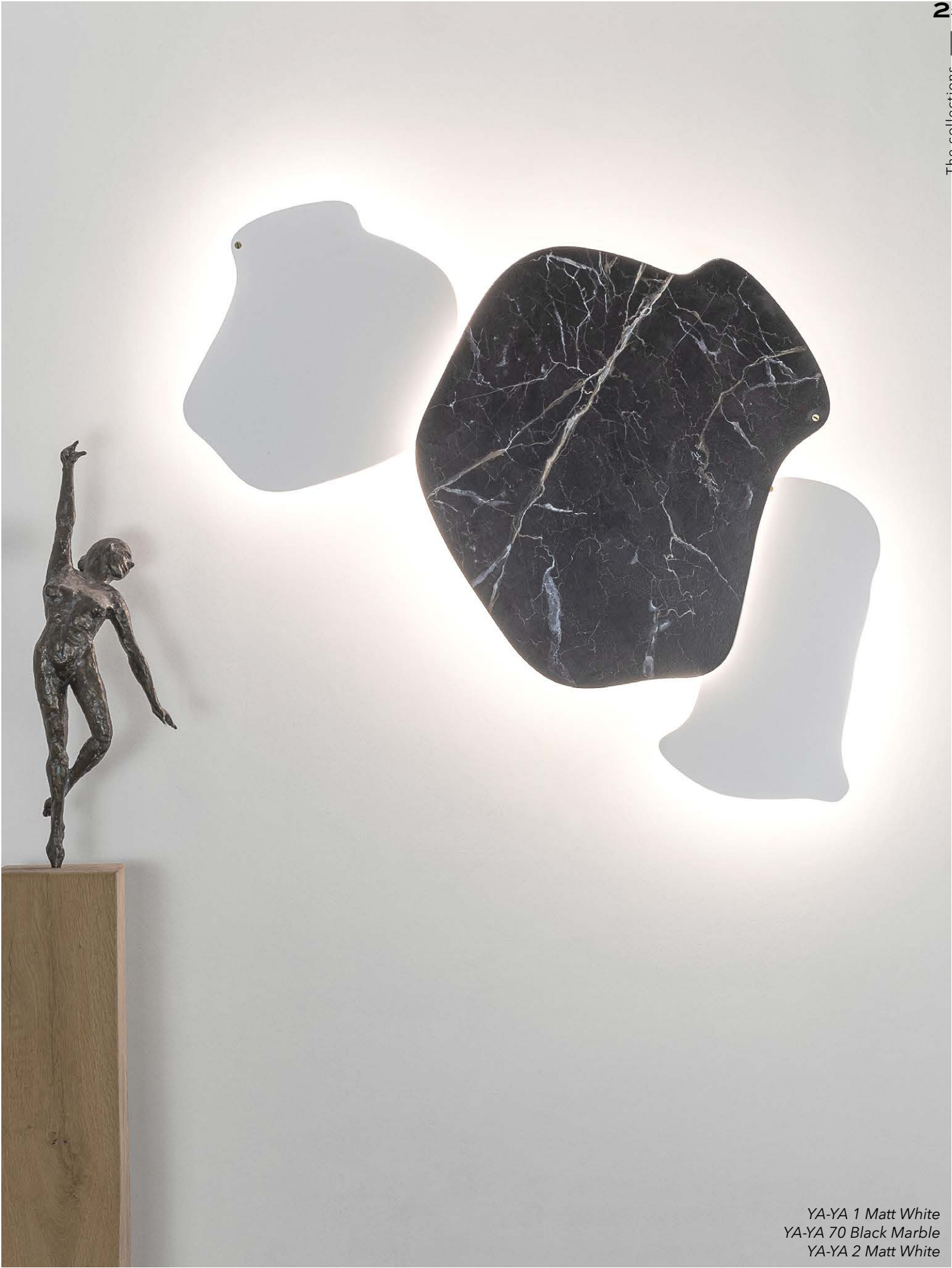

YA-YA 1 Matt White
YA-YA 70 Black Marble
YA-YA 2 Matt White

YA-YA 70 Agathe
YA-YA 1 Matt White





YA-YA 1 *Matt White*
YA-YA 70 *White Marble*
YA-YA 2 *Matt White*

Variations and finishes of
YA-YA



YAYA 70
WHITE MARBLE



YAYA 70
BLACK MARBLE



YAYA 70
AGATHE
(ONLY THIS SIZE)



YAYA 70



YAYA 1



YAYA 2



YAYA 3



Matt
White



Gold
Leaf



Silver
Leaf

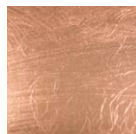

Copper
Leaf



White
Marble



Black
Marble

Manufacturing & technical details of
YA-YA

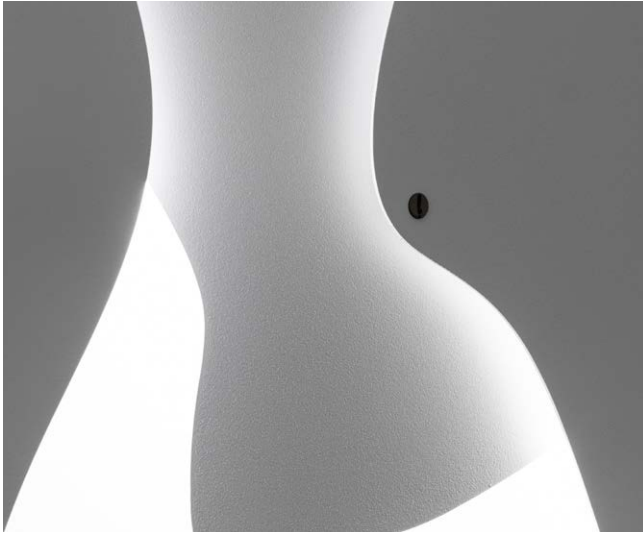

Magic play of light.

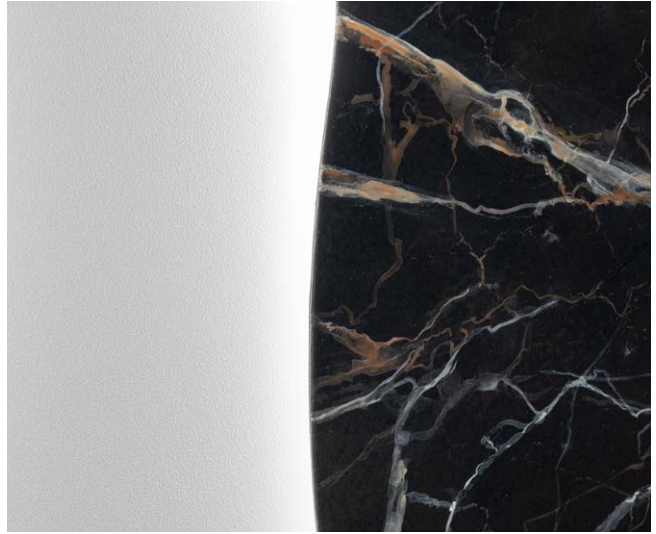

Black marble finish.

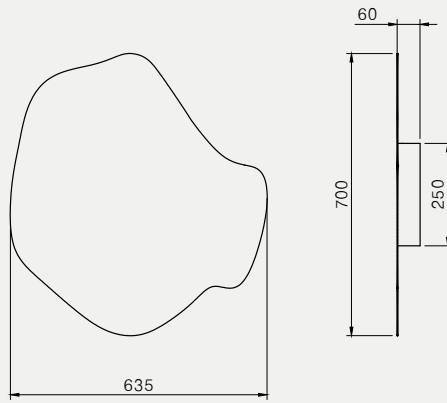

YA-YA 70
Led 18w 2700K 2500lm

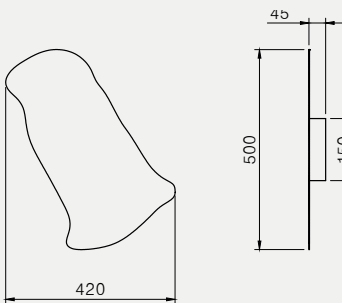

YA-YA 2
Led 10w 2700K 1500lm

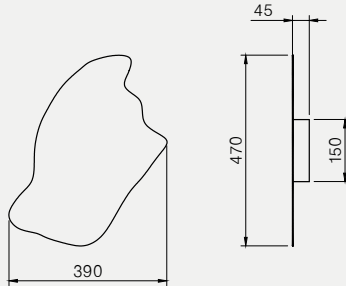

YA-YA 3
Led 10w 2700K 1500lm

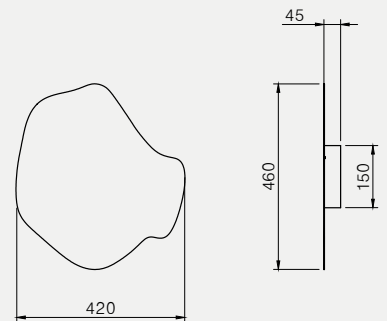

YA-YA 1
Led 10w 2700K 1500lm

FICO

Design by Chiaramonte Marin Studio / 2018

*Like the fruit of the same name (FIG in Italian),
which conceals succulent pulp beneath a thick
skin, here the light is protected by a shell of
ceramic hanging from a tape as if from the
branch of its tree.*

It comes in three different shapes.



Fico 1
Fico 2
Fico 3



Fico 3 White



Fico 1
Fico 2
Fico 3



Fico 1 Black



Fico 1
Fico 2
Fico 3

Variations and finishes of **FICO**



FICO 1



FICO 2



FICO 3

Ceramic



White



Black



Mastic

Belt



White
Leather

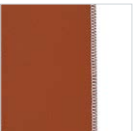

Cognac
Leather



Black
Leather



Pixel
White

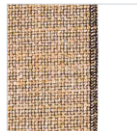

Pixel
Sand



Pixel
Black



Velvet
Black



Velvet
Green

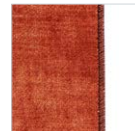

Velvet
Pisé



Ceramic work and hand-sewn leather.



Fine galvanic finish.

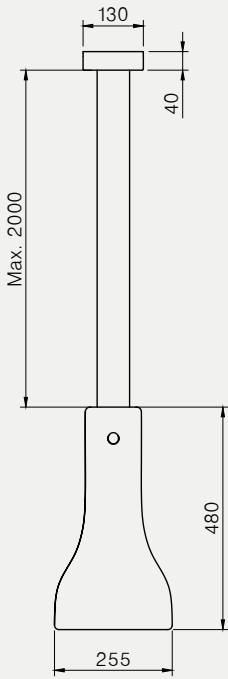

FICO 1
E27 led bulb 13w 2700K 1100lm

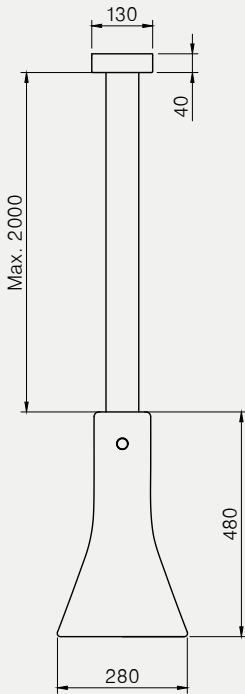

FICO 2
E27 led bulb 13w 2700K 1100lm

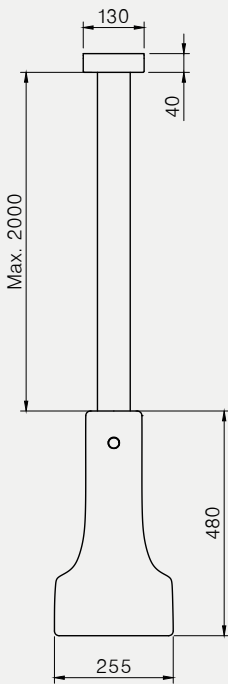

FICO 3
E27 led bulb 13w 2700K 1100lm

MERIDIANA

Design by Chiaramonte Marin Studio / 2018

*Meridiana: this is not a sundial, even
if it mess with light.*

*The process in fact is inverse: here the light
is not the means, but the purpose, a great
disk like the sun and hidden behind a big
clock hand or what it seems like, a gentle,
not blinding light.*



Meridiana Wenge Oak
Meridiana White Marble



Meridiana



Meridiana White Marble
Meridiana Floor White Marble

Variations and finishes of
MERIDIANA



MERIDIANA

Diffusor plate



White
marble



Wenge
oak

Shape



Matt
white

Manufacturing & technical details of
MERIDIANA

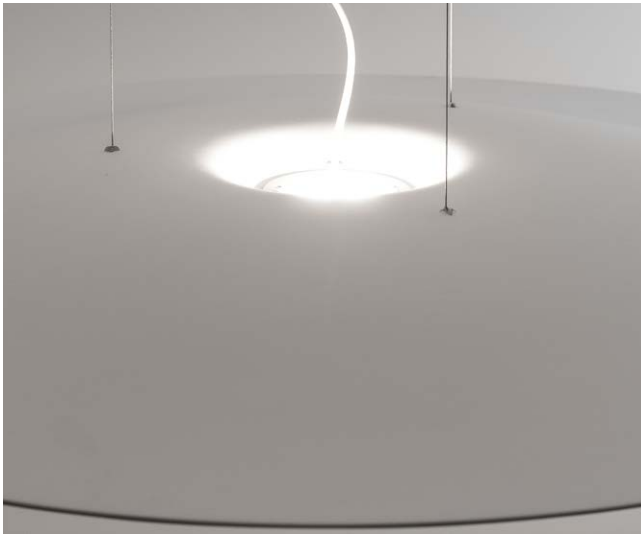

Up and down lighting source.

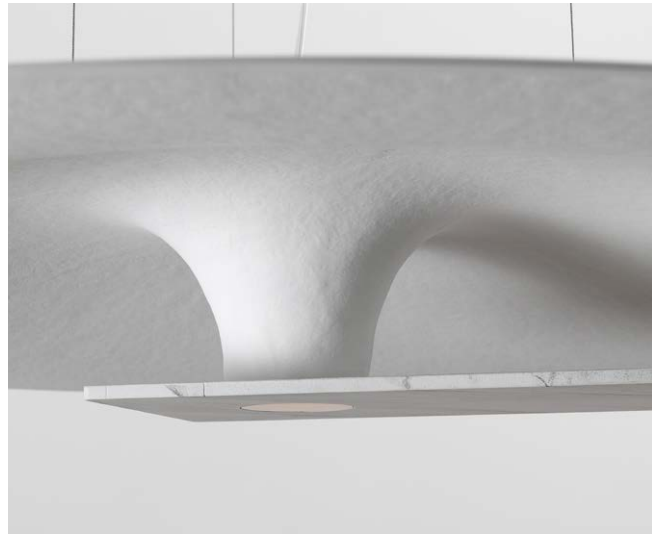

Magic effect with rough fiberglass surface.

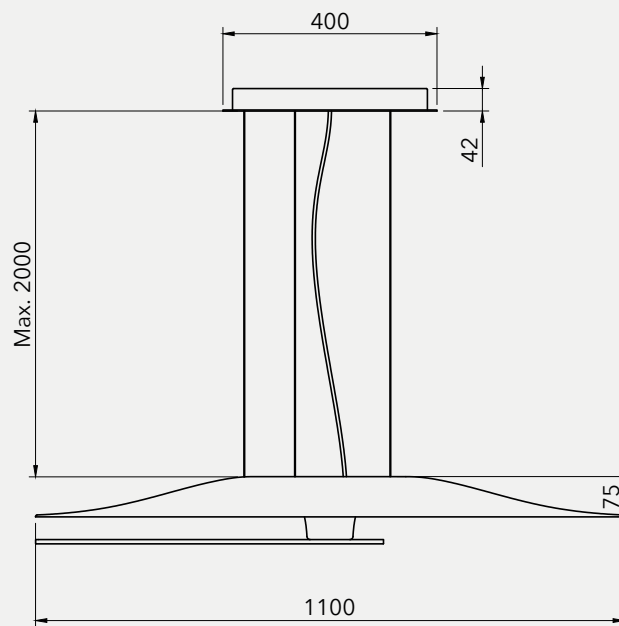

MERIDIANA

IP20 led module 45w 2700K 5000lm

MERIDIANA FLOOR & WALL

Design by Chiaramonte Marin Studio / 2019

*Naturally came the floor and wall version
of Meridiana.*

*The floor version with brushed gold
huge bended piece.*

*And the wall version like a sundial
releasing a soft and non blinding light.*



Meridiana Wall Wenge Oak
Meridiana Floor Wenge Oak



Meridiana Floor



Meridiana Floor White Marble

Variations and finishes of
MERIDIANA



MERIDIANA WALL

MERIDIANA FLOOR

Diffusor plate



White
marble



Wenge
oak

Shape



Matt
white

Manufacturing & technical details of
MERIDIANA

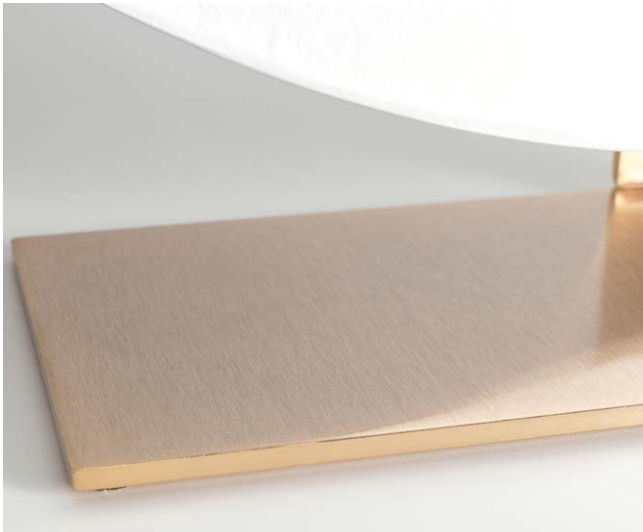

Fine brushed gold base



Back detail Meridiana Floor

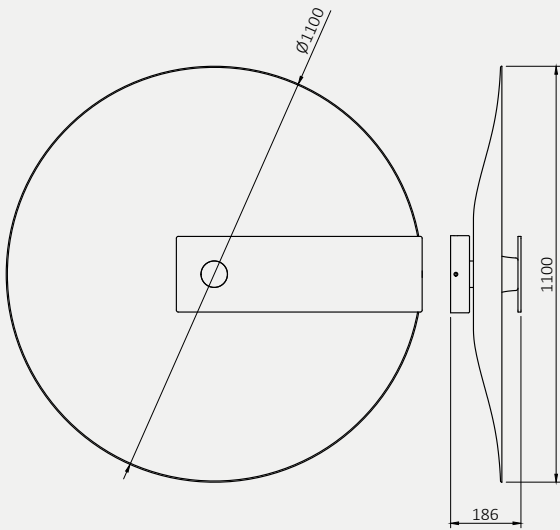

MERIDIANA WALL
IP20 led module 35w 2700K 4000lm

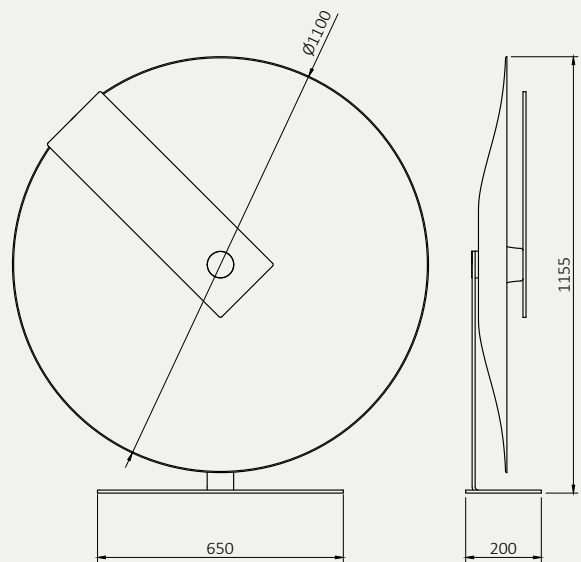

MERIDIANA FLOOR
IP20 led module 35w 2700K 4000lm

T-COTTA

Design by Chiamonte Marin Studio / 2018

Created from the desire to create an object of fluid, curved forms, T-COTTA is the fruit of the union of materials, both of which come from earth, both are worked by man and both forged by heat.



TC4,TC1,TC3,TC2 Black





TC1 Grey
TC3 Grey





T-Cotta Wall

Variations and finishes of
T-COTTA

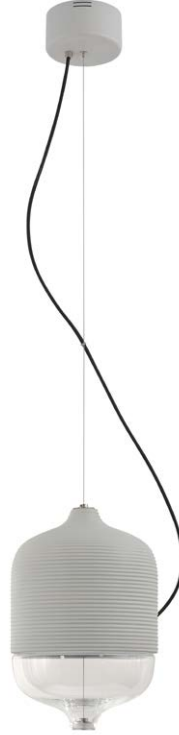

**T-COTTA
TC1**

**T-COTTA
TC2**

**T-COTTA
TC3**

**T-COTTA
TC4**

Ceramic cap



Terracotta



Black



Grey



Green

Glass



Glass
clear



Opalino
glass



Ceramic in natural terracotta color.



Harmony between glass and ceramic.

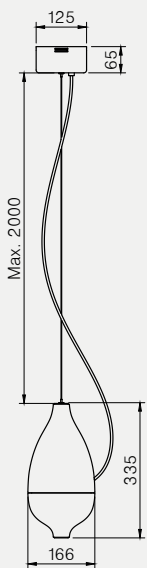

TC1
 Led module 8w
 2700K 1000lm

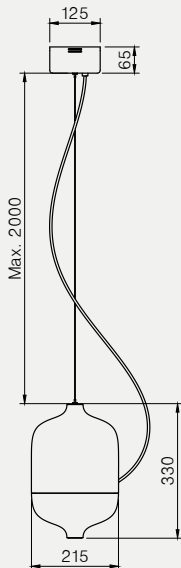

TC2
 Led module 8w
 2700K 1000lm

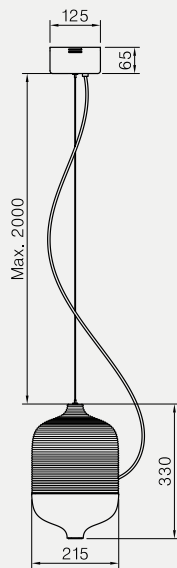

TC3
 Led module 8w
 2700K 1000lm

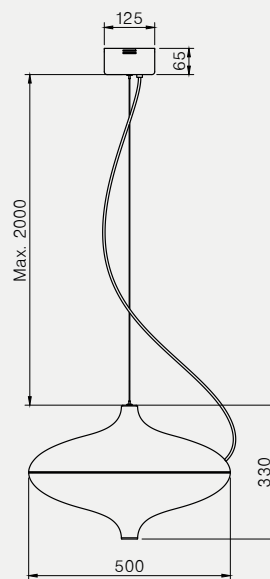

TC4
 Led module 12w
 2700K 1600lm

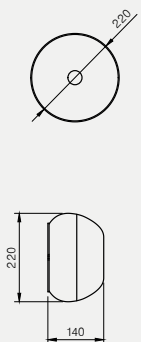

TCW
 Led module 8w
 2700K 1000lm

T-COTTA THE LAMP

Design by Chiaramonte Marin Studio / 2019

*Carrara marble from Pietrasanta
and solid brass like a diamond on a ring, are
the elements that sublimate
T-Cotta The Lamp.*



T-Cotta TS Pink
T-Cotta TM Black
T-Cotta FL Black



*T-Cotta FL Black
T-Cotta TS Black
T-Cotta TM Pink*





T-Cotta The Lamp



T-Cotta FL Black
T-Cotta TM Black
T-Cotta TS Black
T-Cotta TS Green
T-Cotta TM Pink

Variations and finishes of
T-COTTA THE LAMP



**T-COTTA
TS**



**T-COTTA
TM**



**T-COTTA
FL**

Color



Pink



Green



Black

Glass



Glass
clear

Manufacturing & technical details of
T-COTTA THE LAMP



Black chrome detail on solid brass.



Smooth pink rough finish.

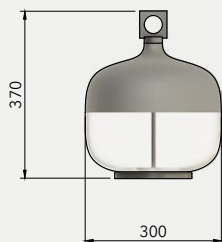

T-COTTA TS
Led module 12w
2700K 1500lm

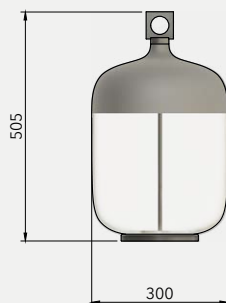

T-COTTA TM
Led module 12w
2700K 1500lm

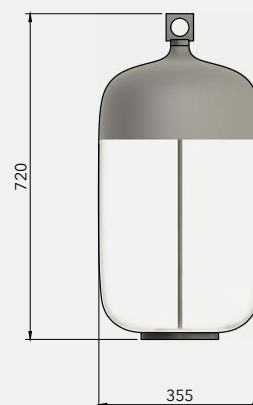

T-COTTA FL
Led module 12w
2700K 1500lm

ICE

Design by Hind Rabii / 2015

A non-Belgian may not yet be able to imagine an ICE, a sweet (praline in «Belgian») melting on the tongue and which, after the initial asperity, releases a flow of praline chocolate down the throat. The ICE enjoys that kind of roundness that captures the senses, brimming with excitement.

It is bursting with light, ready to explode in every direction or to be encased in its desires by golden or silver corsets. ICE is as asteroid of light coming from nowhere, coming from elsewhere.

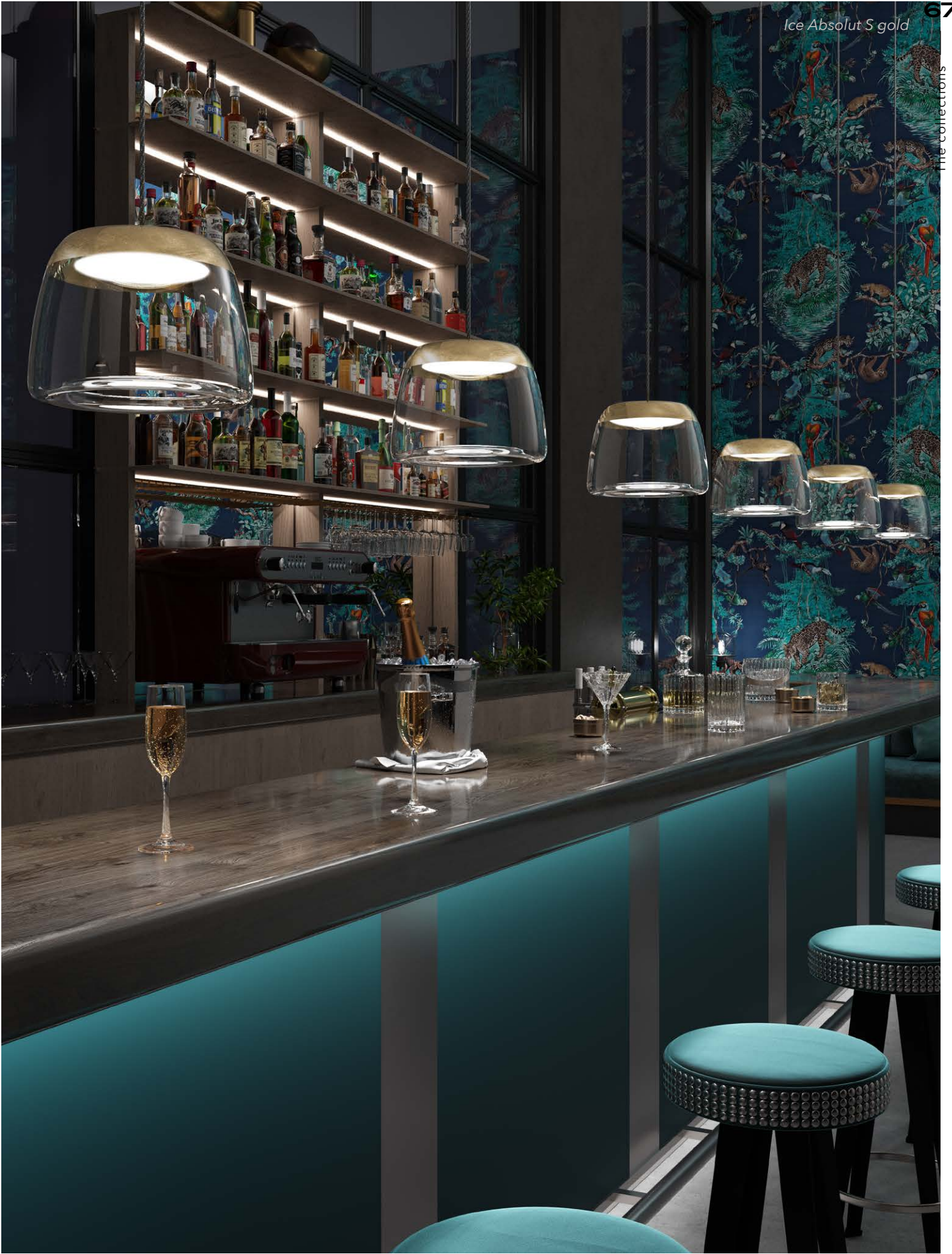

Ice Absolut S gold
Ice Absolut S silver





*Ice Absolut S gold
Ice Absolut L gold*

Variations and finishes of
ICE ABSOLUT

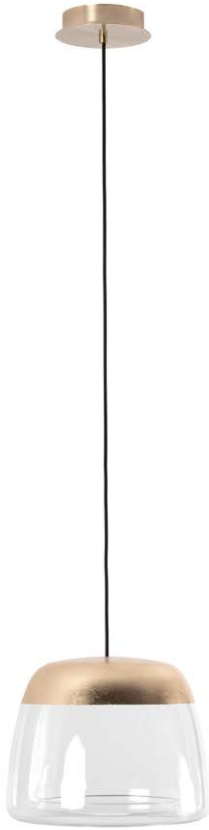

ICE ABSOLUT S

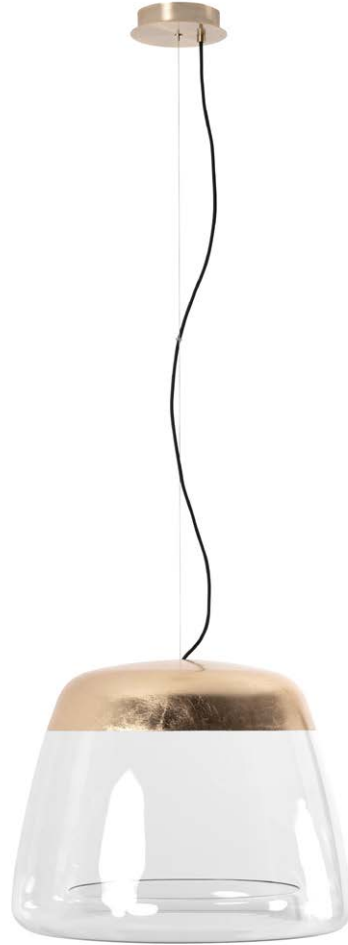

ICE ABSOLUT L



Gold
Leaf



Silver
Leaf



Copper
Leaf

Manufacturing & technical details of **ICE ABSOLUT**



Exceptional technical glasswork



Artisanal laying of copper leaf.

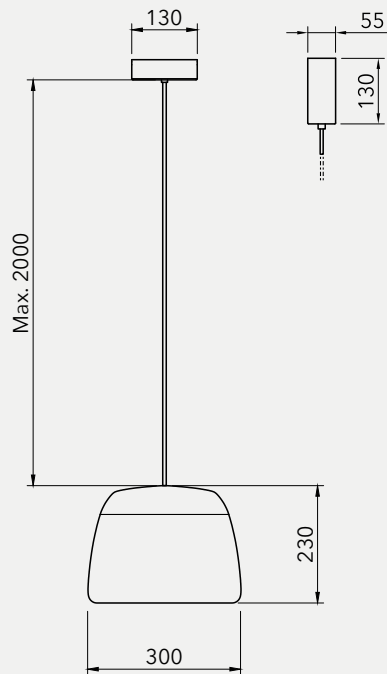

ICE ABSOLUT S
IP20 led module 10w 2700K 1000lm
Canopy flat or tube

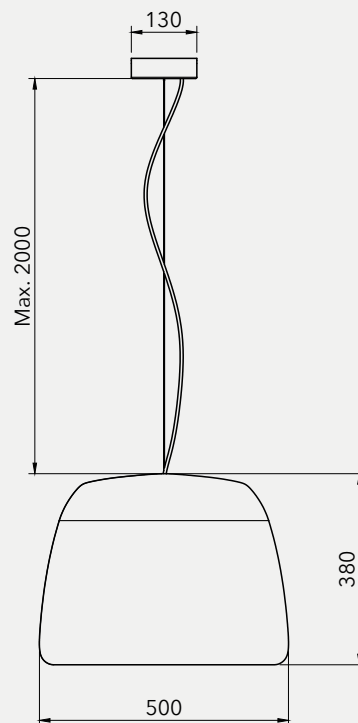

ICE ABSOLUT L
IP20 led module 17w 2700K 1700lm

ICE DEVOTION

Design by Hind Rabii / 2017

Directly inspired from Ice Absolut, Ice Devotion's glass is mouth blown in clear, fumé and light pink.

Like a construction, the base made in solid oak makes Ice Devotion, the exact reflection of Ice Absolut.

Ice Devotion S Pink
Ice Devotion L Nature Clear
Ice Devotion S Wenge Fumé







Variations and finishes of ICE DEVOTION



ICE DEVOTION S

ICE DEVOTION L

Glass finish Ice Devotion S



Clear

Fumé

Opalino

Pink

Wood Finish



Nature

Wengé

Glass finish Ice Devotion L



Clear

Manufacturing & technical details of **ICE DEVOTION**



Solid oak base.



Blown glass with color in mass.

Ice Devotion S Opalino

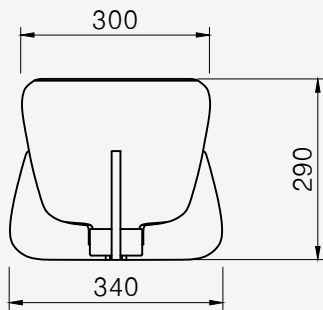

ICE DEVOTION S
IP20 led module 8w 2700K 800lm

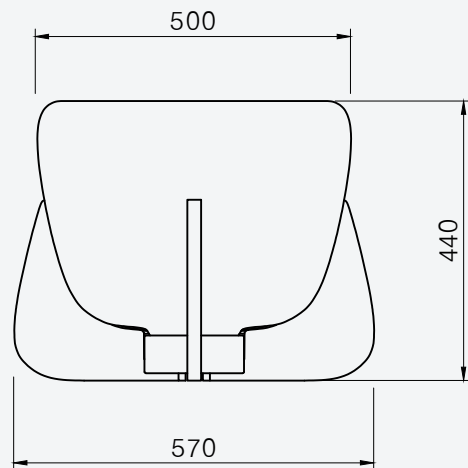

ICE DEVOTION L
IP20 led module 10w 2700K 1000lm

ICE

Design by Hind Rabii / 2015

*Definitely modern interpretation of Ice
in this version.
Made in aluminium, soft touch anodisation
finish gives to Ice, this extra matt
smooth color.*



Ice 15
Ice Lady



Ice 15 White
Ice 15 Blue



*Ice 15 White
Ice Lady White*

The ceiling variations and finishes of
ICE



ICE 15



ICE LADY

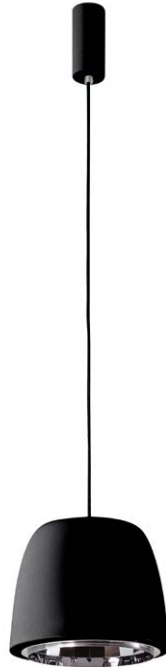

ICE 24



ICE-T

Outer shell



Black
anodized

Orange
anodized

Green
anodized

Blue
anodized

Matt
white

Reflector

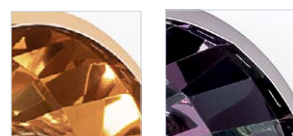

Copper

Carbon



Smooth anodized color effect.



Maximum light reflection.

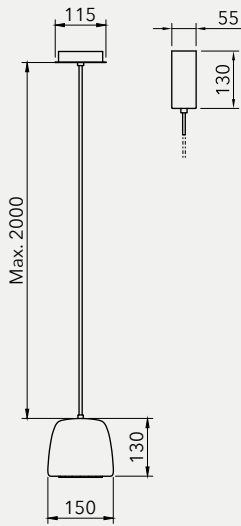

ICE 15
IP20 led module 8w 2700K 800lm
Canopy flat or tube

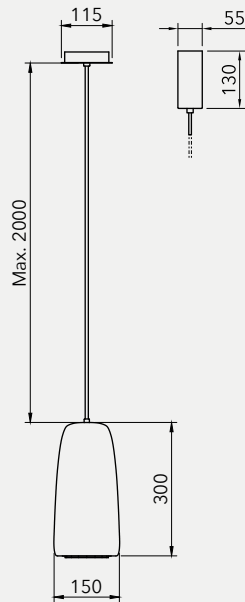

ICE LADY
IP20 led module 8w 2700K 800lm
Canopy flat or tube

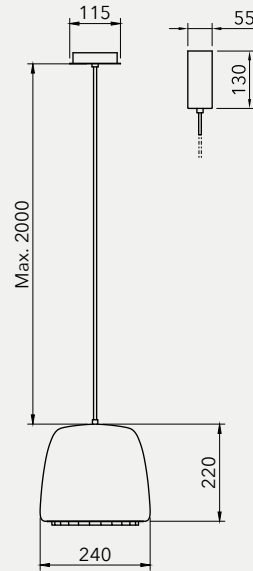

ICE 24
IP20 led module 10w 2700K 1000lm
Canopy flat or tube

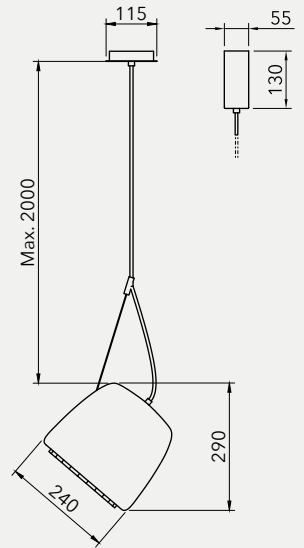

ICE-T
IP20 led module 10w 2700K 1000lm
Canopy flat or tube

ICE DONNA

Design by Hind Rabii / 2017

*Donna in Italy means Lady.
Ice Donna has an elegant silhouette,
a mix of style and character.
A base in solid brass and a reflector made
in aluminium are technical highlights of this
Lady.*



Variations and finishes of ICE DONNA



ICE DONNA S

ICE DONNA L

Cap light



Black & carbon



Black & copper



White & carbon



White & copper

Structure

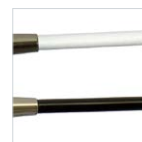

White or black tube

Manufacturing & technical details of
ICE DONNA



High quality finishing.



Solid brass base.

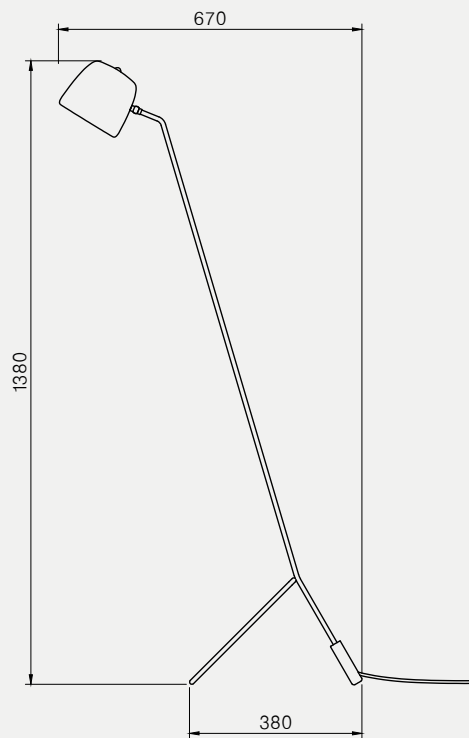

ICE DONNA L
IP20 led module 8w 2700K 800lm

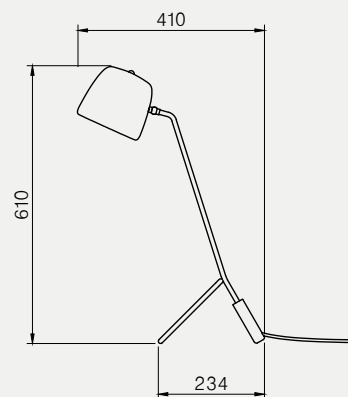

ICE DONNA S
IP20 led module 8w 2700K 800lm

ICE WALL

Design by Hind Rabii / 2017

Like a sun, Ice Wall projects its rays from different places thanks to his free moving arm.



Ice A120 White Copper
Ice A58 White Copper

The wall variations and finishes of
ICE



ICE A120



ICE A58



ICE A78

Cap light



Black & carbone



Black & copper



White & carbone

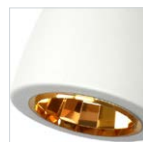

White & copper

Structure



White or black tube



Ice A30

Technical details of **ICE**

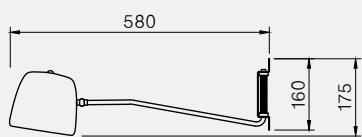

ICE A58

IP20 led module 8w 2700K 800 lm

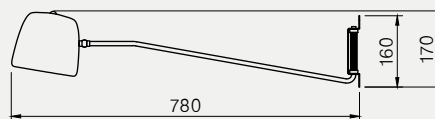

ICE A78

IP20 led module 8w 2700K 800 lm

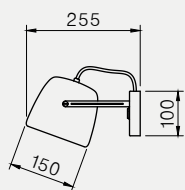

ICE A30

IP20 led module 8w 2700K 800 lm

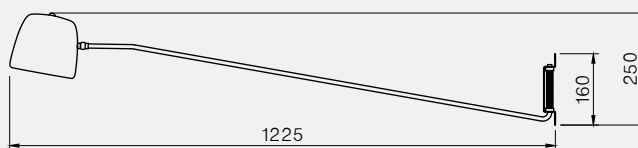

ICE A120

IP20 led module 8w 2700K 800 lm

BELLE D'I

THE GREAT EDITION

Design by Hind Rabii - 2019

For this collection, Hind Rabii drew her inspiration from the characteristic shape of Morocco's traditional Beldi glass for tea and infusions.

The simple, clean lines of the pendant are contrasted with the material quality of the glass, obtained by means of mouth blown techniques.

A timeless lamp: stylish and original, it blends perfectly into any environment, whether classic or contemporary, to create a warm, evocative atmosphere.







Belle d'I The Great Edition Fumé

Variations and finishes of
BELLE D'I THE GREAT EDITION



**BELLE D'I THE GREAT
EDITION CLEAR**

**BELLE D'I THE GREAT
EDITION FUMÉ**



Shiny
nickel



Shiny
gold



Glass
clear



Glass
fumé

Manufacturing & technical details of
BELLE D'I THE GREAT EDITION



Matt opalin mouth blown glass.



Specific design in metal work.

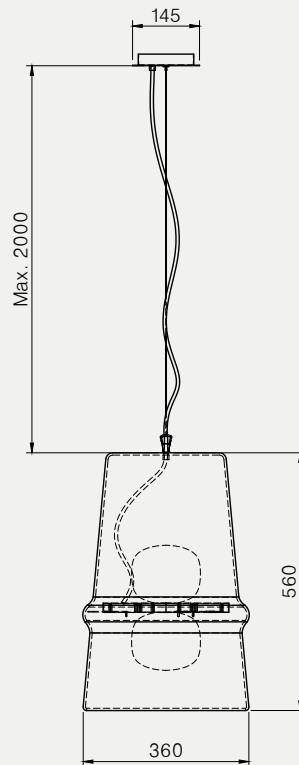

BELLE D'I THE GREAT
IP20 G9 led bulb 2 x 5w 2700K 900 lm

DISCA

Design by Alberto Nason / 2017

*Sometimes a luminous apparition seems to
come from elsewhere.*

*In green, transparent white, milky or transparent
lava glass, DISCA expresses itself fully in any
defined or virtual place.*

*Its flashes of light carry its shapes off to infinity,
as they spin on themselves in a Venetian vortex
or a Viennese Waltz.*



*Disca S green
Disca L clear
Disca S clear*

Disca L White
Disca S White





Disca L Green





RABII

Disca Amber

Variations and finishes of
DISCA



DISCA S



DISCA L



DISCA T

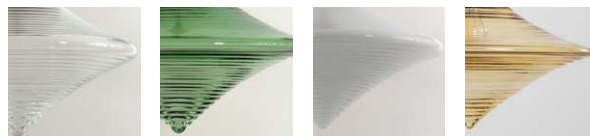

Clear

Green

White

Amber



Brushed gold finish.

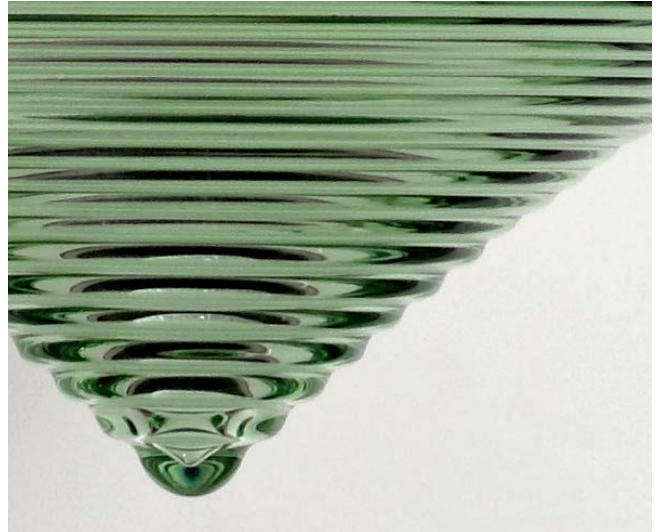

Glass colored in the mass.

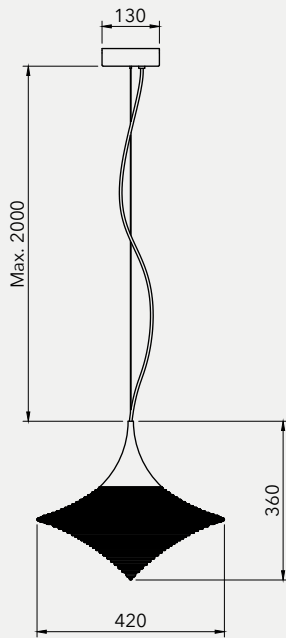

DISCA S

IP20 E27 led bulb 10w 2700K 1100 lm

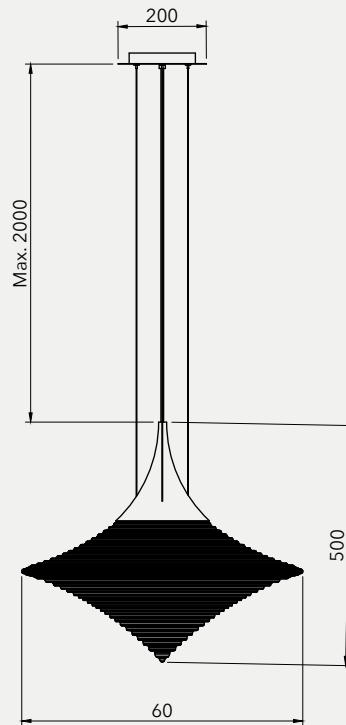

DISCA L

IP20 E27 led bulb 13w 2700K 1500 lm

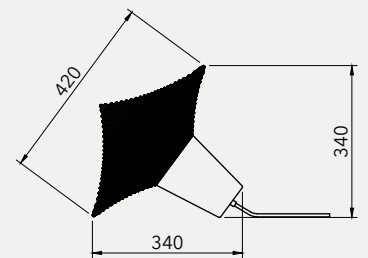

DISCA T

IP20 E27 led bulb 6w 2700K 600 lm

REFLECTOR(S) TENSION(S)

Design by Hind Rabii / 2014

REFLECTOR(S), collection of pendants and wall lamps, with an ample choice of heights and diameters, so that the lamps can be combined to create light effects of varying intensity.

Cylindrical shade made from velvet or printed fabric in different variants. Metal reflector with aluminium in copper and carbon finish.

TENSION(S), creation of Hind Rabii, this pendant for indoor use features a fabric shade and an adjustable cone-shaped aluminium reflector in copper or carbon color for direct and indirect light.

With its contemporary linear design, it can be used in various positions and at different heights, so as to obtain an interesting interplay of light and shapes.



*Tension Ceramic copper
Tension Martel Silver copper*

Variations and finishes of TENSION(S)



TENSION(S) COPPER

TENSION(S) CARBON

Inner finishes

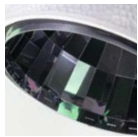
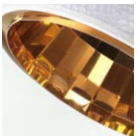

Copper

Carbon

Cap

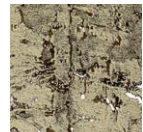
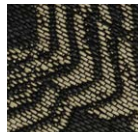
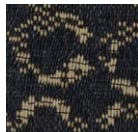
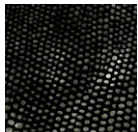

Martel silver

Martel black

Ceramic

Mémoire black

Spirit

Namea

Arsen

Masai

Luxe Silver

Ecorce

Manufacturing & technical details of
TENSION(S)



Fabric with ceramic inserts.



Metal effect fabric.

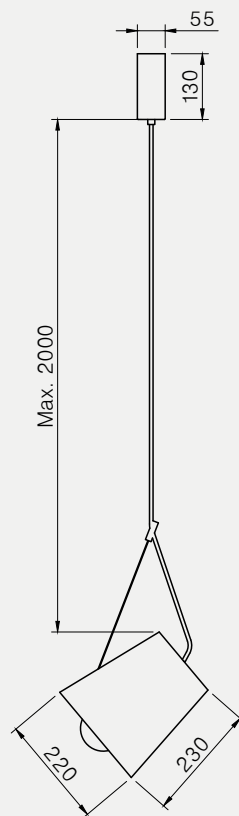

TENSION(S)
G9 led bulb 5w 2700K 500 lm

Reflector RLC235 Namea
Reflector RLC218 Arsen
Reflector RLC250 Masai
Reflector RLC140 Spirit





Reflector RLC140 Ecorce
Reflector RLC250 Luxe Silver
Reflector RLC218 Luxe Silver
Reflector RLC235 Ecorce

Reflector wall carbon Martel Silver





*Top Reflector TPR118 carbon Martel Black
 Top Reflector TPR125 carbon Martel Silver
 Top Reflector TPR216 carbon Martel Silver*

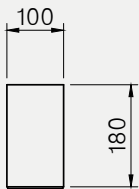

TPR118 copper
 TPR118 carbon
 Led 8w 2700K 800lm

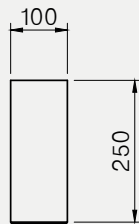

TPR125 copper
 TPR125 carbon
 Led 8w 2700K 800lm

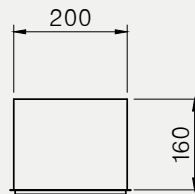

TPR216 copper
 TPR216 carbon
 Led 8w 2700K 800lm

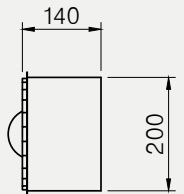
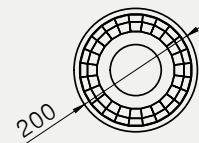

Reflector wall copper
 Reflector wall carbon
 G9 led bulb 5w 2700K 500lm

Variations and finishes of
REFLECTOR(S)



RLC 130

RLC 235

RLB 140

RLB 250

Inner finishes

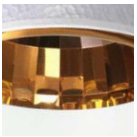

Copper
RLC

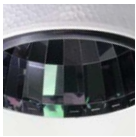

Carbon
RLB

Cap



Martel
silver



Martel
black



Ceramic

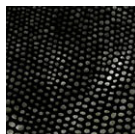

Mémoire
black



Spirit

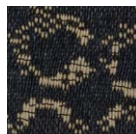

Namea

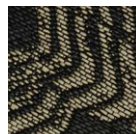

Arsen



Massai

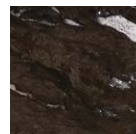

Luxe
Silver



Ecorce



Reflector wall copper Martel Silver
 Reflector wall copper Ceramic
 Reflector wall copper Martel Black

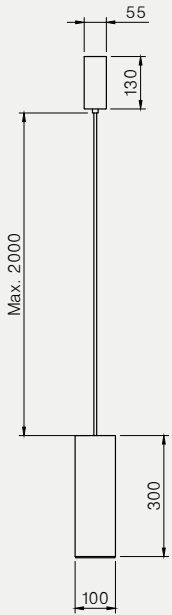

RLC 130
RLB 130
 IP20 led module 8w
 2700K 800lm

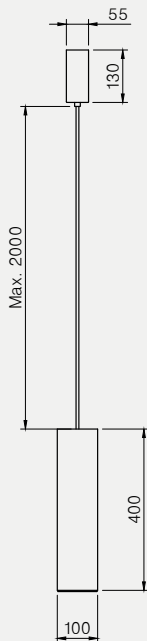

RLC 140
RLB 140
 IP20 led module 8w
 2700K 800lm

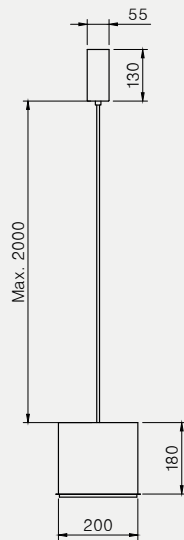

RLC 218
RLB 218
 IP20 led module 8w
 2700K 800lm

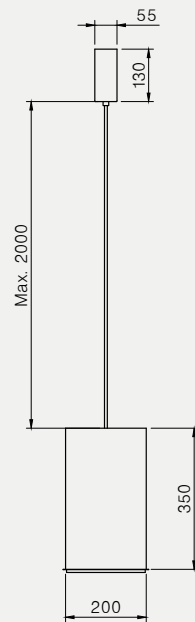

RLC 235
RLB 235
 IP20 led module 8w
 2700K 800lm

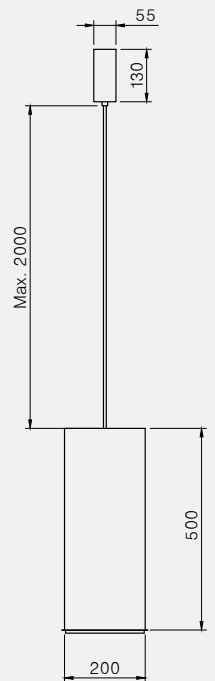

RLC 250
RLB 250
 IP20 led module 8w
 2700K 800lm

ANNA BELLE

Design by Hind Rabii / 2016

ANNA-BELLE is endowed with an extremely rare elegance. The textiles enjoy a whiteness nuanced by the material used and the crown says a little too much of the purity of its intentions.

For BELLE, seducing you is banal.

The oak, an eternal and timeless material, turned towards MORANDI, is the only «support» that suits it. It'll give your home a presence that's both luminous and strong.

Anna Belle 2
Anna Belle 3
Anna Belle 5





Anna Belle 2
Anna Belle 3
Anna Belle 5



Anna Belle 5

Variations and finishes of
ANNA BELLE



ANNA BELLE 5



ANNA BELLE 2



ANNA BELLE 3



First choice plain oak.



Shade in white cotton with diffusor.

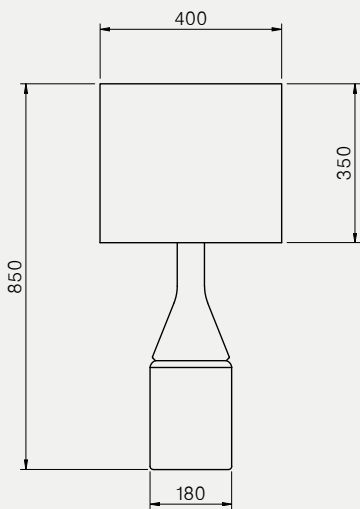

ANNA BELLE 3
IP20 E27 led bulb 13w
2700K 1500lm

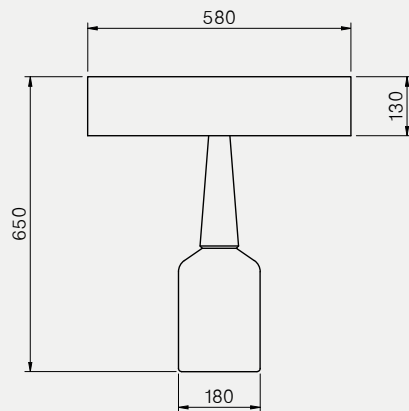

ANNA BELLE 2
IP20 E27 led bulb 3x10w
2700K 2400lm

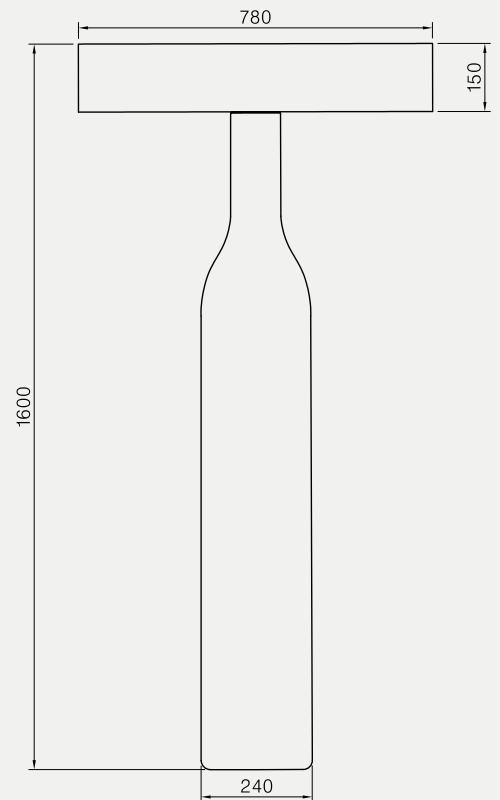

ANNA BELLE 5
IP20 E27 led bulb 3x10w
2700K 2400lm

3 X 3 X 3

Design by Hind Rabii / 2015

*Combination of three shapes inspired by nature,
mountains and childhood : the bell, the spinning
top and the cheese wheel.*

*The three shapes come in three different finishes.
The metal is brushed for the most beautiful effect
and the glass is sublimated by the use of leaf.*



M1-GLASS-T silver
T1-GLASS-T gold
C1-GLASS-T gold

M1-GLASS-T silver





T1-GLASS-T gold

M1-GLASS-T silver
C1-GLASS-T copper







T1-GLASS-T White opalin
C1-GLASS-T White opalin

T1-GLASS-T White opalin
T1-360 White opalin



Variations and finishes of
3 X 3 X 3 GLASS

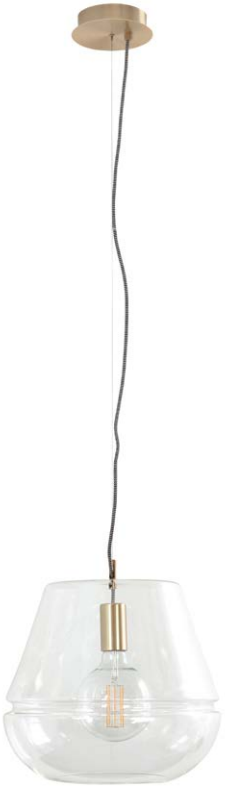

T1-GLASS-T

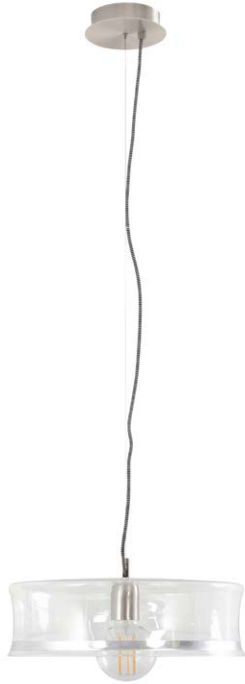

M1-GLASS-T



C1-GLASS-T



T1-360



Silver
leaf



Gold
leaf



Copper
leaf



White
opalin

Manufacturing & technical details of 3 X 3 X 3 GLASS



Elegant glass curves.



Finest handmade leaf finishing.

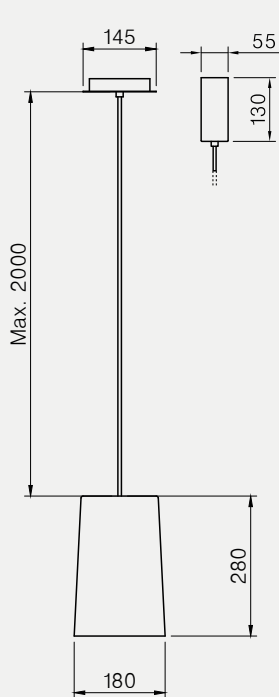

C1-GLASS-T
IP20 E27 G95 led bulb 5w
2500K 450lm

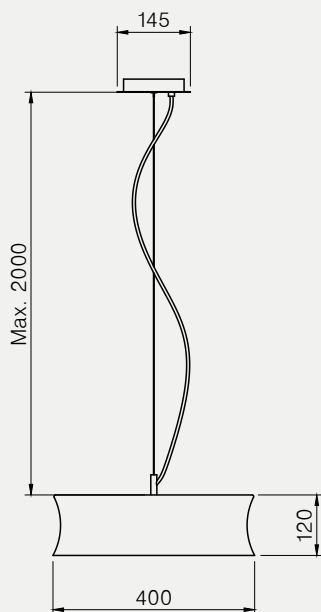

M1-GLASS-T
IP20 E27 G95 led bulb 5w
2500K 450lm

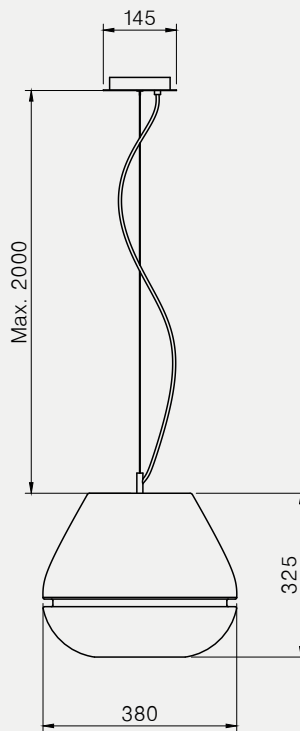

T1-GLASS-T
IP20 E27 G95 led bulb 5w
2500K 450lm

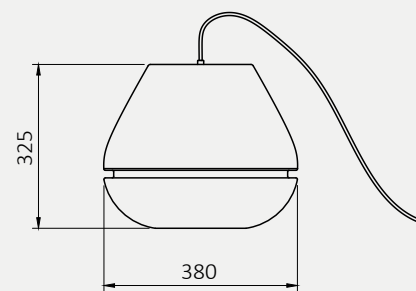

T1-360
IP20 E27 G95 led bulb 5w
2500K 450lm





C1
M1



C1-WALL
C1



C1-WALL

Variations and finishes of
3 X 3 X 3

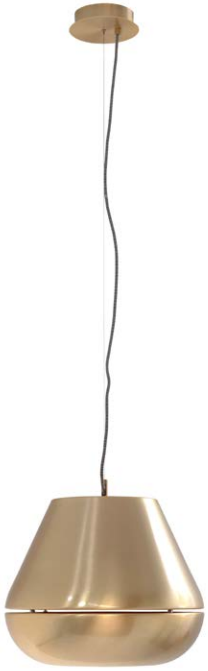

T1

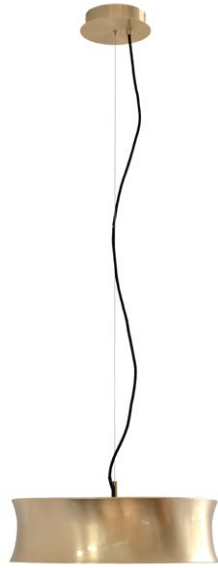

M1



C1



C1-WALL





Finest brushed metal.



Curve detail for C1 shape.

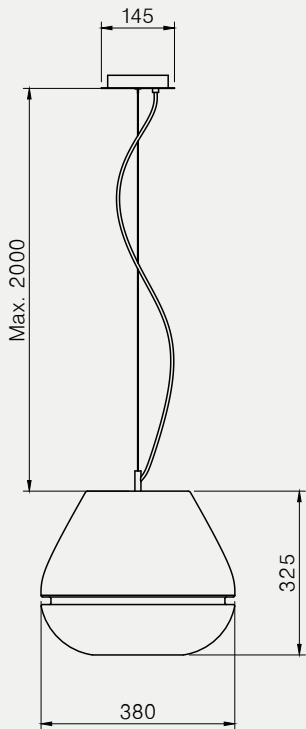

T1
 IP20 E27 GLS60 led 15w
 2700K 1500lm

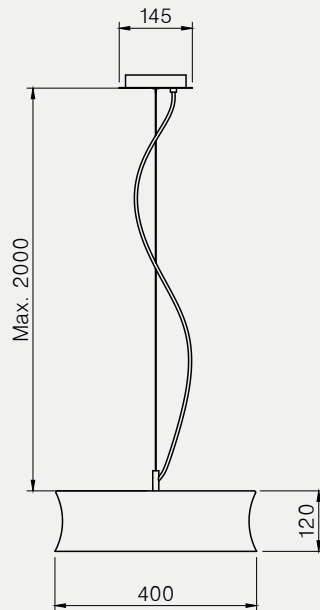

M1
 IP20 led module 10w
 2700K 1000lm

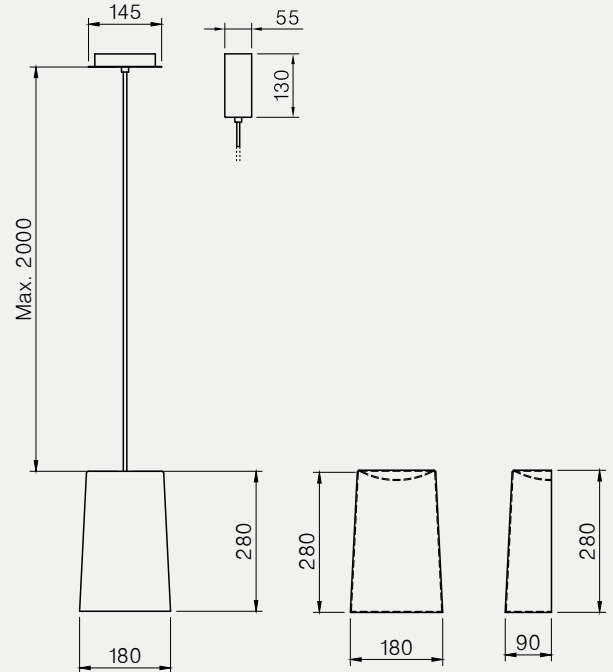

C1
 IP20 E27 GLS60 led 10w
 2700K 810lm

C1-WALL
 IP20 g9 led 2x5w
 2700K 900lm

TENUE DE SOIREE

Design by Hind Rabii / 2015

The visual impacts of TENUE DE SOIREE are impressed in large-scale on the emotion.

They open up the space to romantic, phantasmagorical figures and surround the light with graphic vibrations selected by Hind Rabii for their ability to stir up.

Luminous emotions that carve out for themselves spaces reserved for places with extraordinary stories. Concert halls, restaurants in historic palaces, reception rooms of hôtels particuliers, dining rooms or private bedrooms that, thanks to TENUE DE SOIREE become exceptional places for exceptional personalities.



WLG3600 Opalin - Massai
WLG3000 Opalin - Nappa
WLG3000 Opalin - Namea



WLG3000 Opalin - Voile
WLG3000 Opalin - Forest



WLG3000 Rouille - Ficelle
WLG3000 Opalin - Bambou
WLG3000 Opalin - Madagascar

Variations and finishes of
TENUE DE SOIRÉE



WLG3000
 ROUILLE - BRASIL



WLG3000
 OPALIN - MADAGASCAR



WLG3000
 OPALIN - PÉROU



WLG3000
 OPALIN - ILLUSION BLANC



WLG3000
 OPALIN - SMOOTH



WLG3000
 OPALIN - FOREST



WLG3000
 BRUGES - STEAM



WLG3000
 OPALIN - VOILE



WLG3000
 COPPER - VOILE



WLG3000
 OPALIN - NAPPA



WLG3000
 OPALIN - NAMEA



WLG3600
 OPALIN - MASSAI



WLG3000 Opalin - Illusion blanc

Technical details of
TENUE DE SOIRÉE

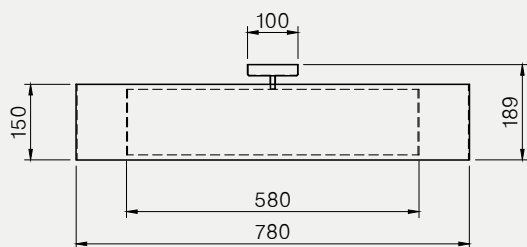

WLG3000
IP20 E27 led bulb 3x10w
2700K 2400lm

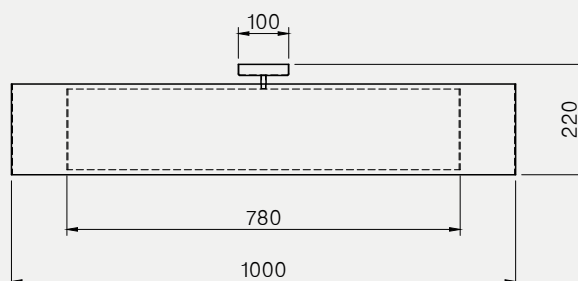

WLG3600
IP20 E27 led bulb 3x15w
2700K 4500lm

KTG2000 Opalin - Voile
KTG2000 Opalin - Forest





KTG3000 Opalin - Massai

Variations and finishes of
TENUE DE SOIRÉE



KTG2000
BRUGES - STEAM



KTG3000
COPPER - VOILE

	Opalin	Opalin	Opalin	Bruges	Opalin	Copper	Opalin	Opalin	Opalin
In									
Out									
	Illusion blanc	Smooth	Forest	Steam	Voile	Voile	Nappa	Namea	Massai

Manufacturing & technical details of
TENUE DE SOIRÉE



Play of light by transparency.



Chic transparent linen.

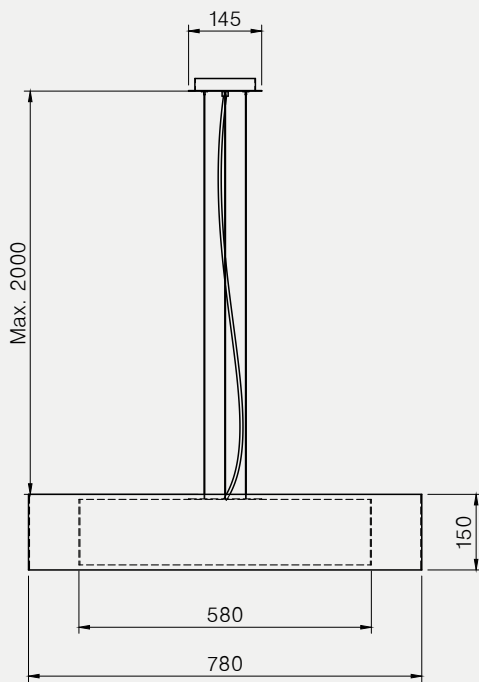

KTG2000
IP20 E27 led bulb 3x10w
2700K 2400lm

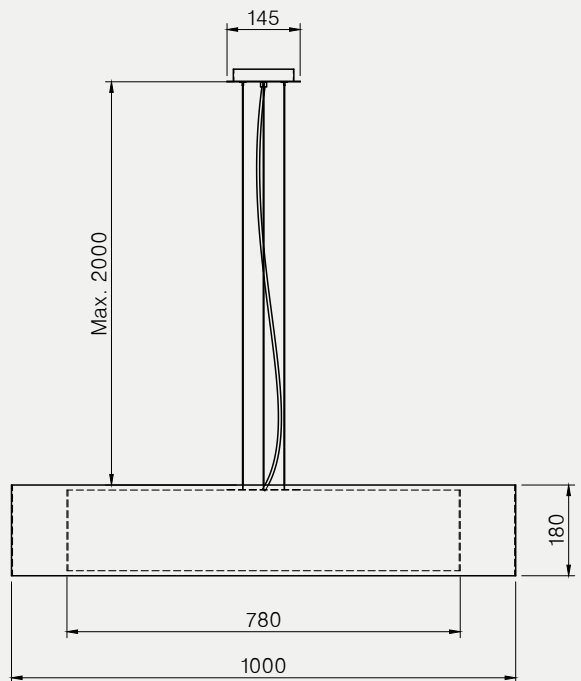

KTG3000
IP20 E27 led bulb 3x15w
2700K 4500lm



TS70 Jane Blue
TS70 Casa Nera



Variations and finishes of
TENUE DE SOIRÉE



TS70
CASA BIANCA



TS70
CASA NERA



TS70
JANE BLUE



Casa
Bianca

Casa
Nera

Jane
Blue

Manufacturing & technical details of
TENUE DE SOIRÉE



Inner matt gold finish.



Finest velvet fabric.

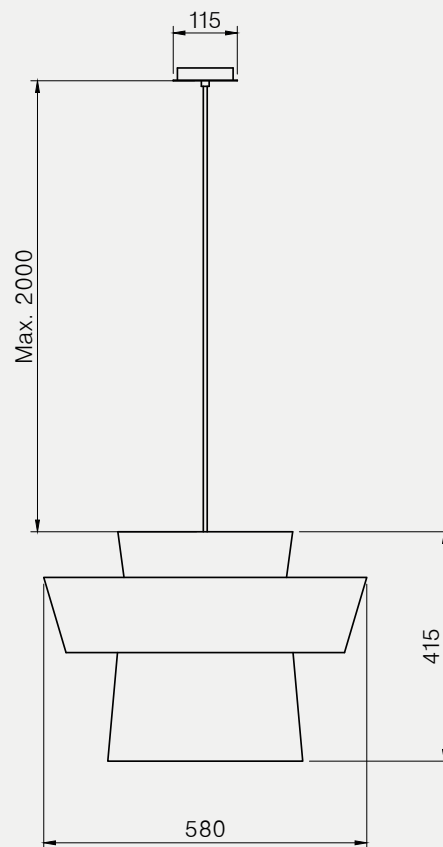

TS70

IP20 E27 GLS60 led 15w
2700K 1500lm

JEWELS - NEWELS

Design by Hind Rabii / 2014

JEWELS, the latest "Jewel" by Hind Rabii is a refined, essential pendant, made of thin sheet metal available in a range of finishes: copper, gold, silver and black. Like a jewel, it shines with its own light thanks to a luminous body with a warm or cool LED light. A unique artistic creation that is a precious addition to any environment.

NEWELS, a suspension lamp whose silhouette reminds that of a lance, made in shaped metal and available in copper, gold and black finishes; being compact and minimal, it plays its role thus maintaining an helpful and discreet presence.



Jewel 35 - Shiny Gold
Jewel 45 - Shiny Gold
Newel - Shiny Gold





Jewel 35 - Shiny Copper
Jewel 45 - Shiny Copper
Newel - Shiny Copper



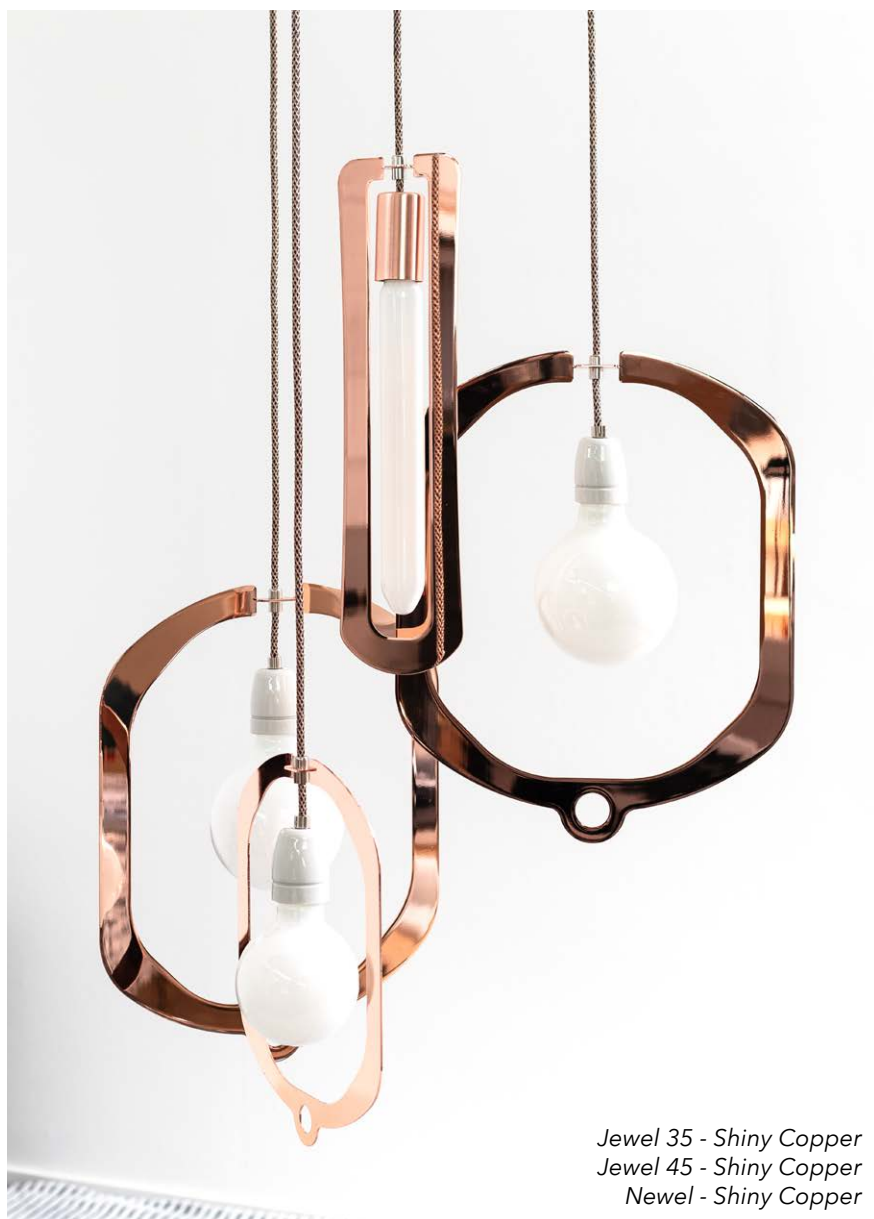

Jewel 35 - Shiny Copper
Jewel 45 - Shiny Copper
Newel - Shiny Copper



Newel - Shiny Gold
Newel Wall - Shiny Gold



Newel Wall - Shiny Gold
Newel Wall - Shiny Black

Variations and finishes of
JEWEL - NEWEL



JEWEL 35



JEWEL 45



NEWEL



NEWEL WALL



Shiny
Gold



Shiny
Copper



Shiny
Black



High quality galvanic brushed base.



Detail in shape design.

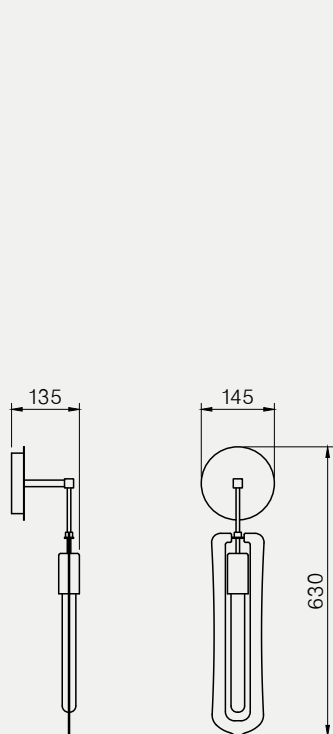

NEWEL WALL
 IP20 E27 T30 led bulb 5w
 opal 2500K 450lm

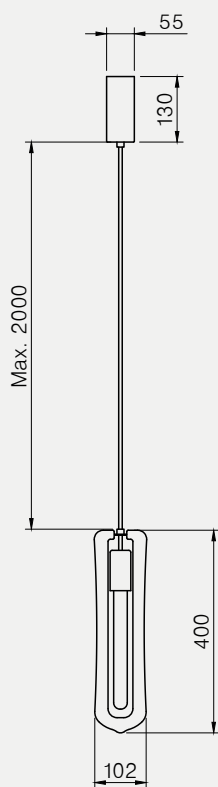

NEWEL
 IP20 E27 T30 led bulb 5w
 opal 2500K 450lm

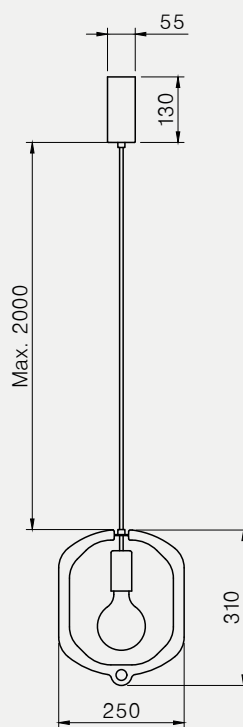

JEWEL 35
 IP20 E27 G95 led bulb 5w
 opal 2500K 450lm

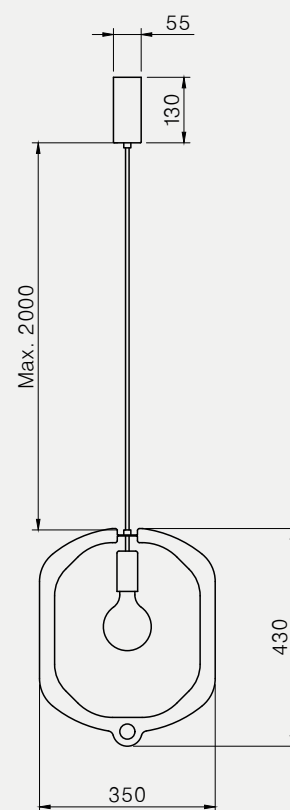

JEWEL 45
 IP20 E27 G125 led bulb 5w
 opal 2500K 550lm

LIGHT GLOW

Design by Hind Rabii / 2018

Simplicity and a focus on materials and the softness of light.

A unique suspension game that, by assembly, will give an imposing but sober pendant lamp. With our suspension solutions, the design is recreated at each assembly.

No rules for this mix of material, color and light bulb, just the limits of imagination.



Light Glow 125 - Gold
Hanging System : HS1-8



Light Glow 125 - White
Light Glow 125 - Brushed Nickel
Hanging System : HS1-8



Light Glow 200 - Gold
Light Glow 160 - Gold
Hanging System : HS1-8



Variations and finishes of
LIGHT GLOW



LIGHT GLOW
125



LIGHT GLOW
200



LIGHT GLOW
160



Brushed
Gold

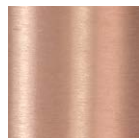

Brushed
Copper

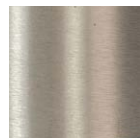

Brushed
Nickel

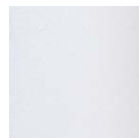

Matt
White



Matt
Black

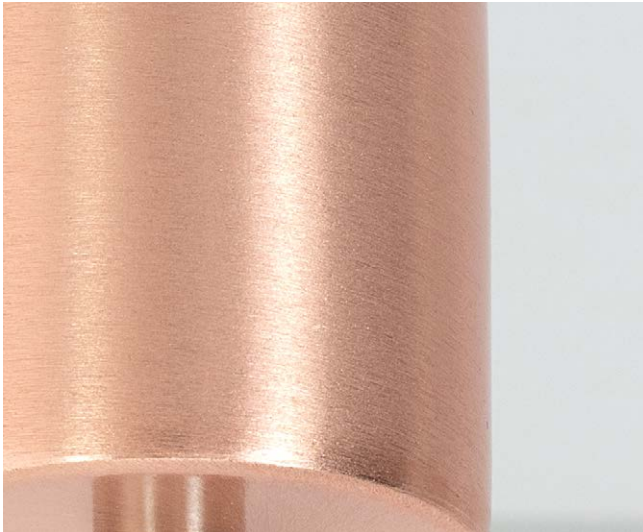

Handcrafted brushed finishes.



Fine structured coating.

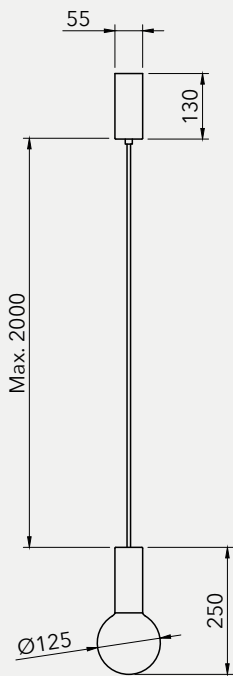

LIGHT GLOW 125
IP20 E27 G125 led bulb 6,5w
opal 2500K 550lm dimmable

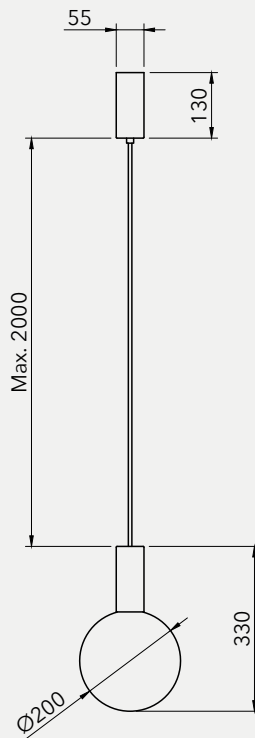

LIGHT GLOW 200
IP20 E27 G160 led bulb 6w
2500K 470lm dimmable

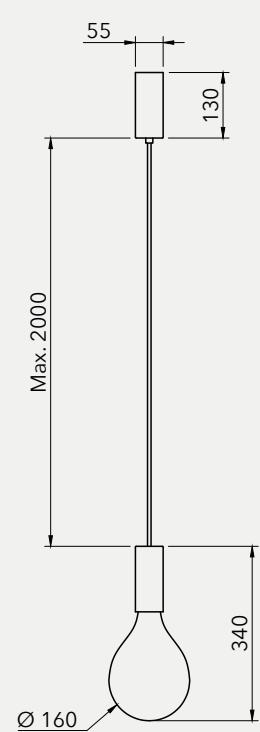

LIGHT GLOW 160
IP20 E27 G160 led bulb 6w
2500K 470lm dimmable

BELLE D'I 20

Design by Hind Rabii / 2015

For this collection, Hind Rabii drew her inspiration from the characteristic shape of Morocco's traditional Beldi glass for tea and infusions, featuring a central band in relief.

The simple, clean lines of the pendant are contrasted with the material quality of the glass, obtained by means of blow-moulding techniques.

Its central box supporting two light sources seems suspended in the air. A timeless lamp: stylish and original, it blends perfectly into any environment, whether classic or contemporary, to create a warm, evocative atmosphere.



Belle d'I 20 Opal Pink
Hanging System : HS1-8



Variations and finishes of
BELLE D'I 20 OPAL WHITE & PINK



**BELLE D'I 20
OPAL WHITE**



**BELLE D'I 20
OPAL PINK**



Opal
White

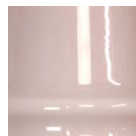

Opal
Pink

Manufacturing & technical details of
BELLE D'I 20 OPAL WHITE & PINK



Special mouth blown glass.



Several glass layers for a unique pink color.

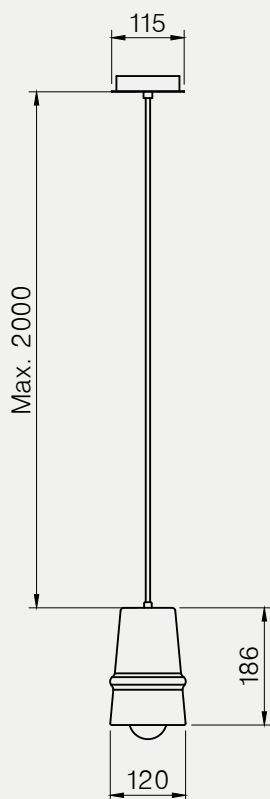

BELLE D'I 20 OPAL
IP20 E27 GLS60 led 10w
2700K 810lm





Belle d'I 20 Empreinte AB60

Technical details of
BELLE D'I 20 EMPREINTE

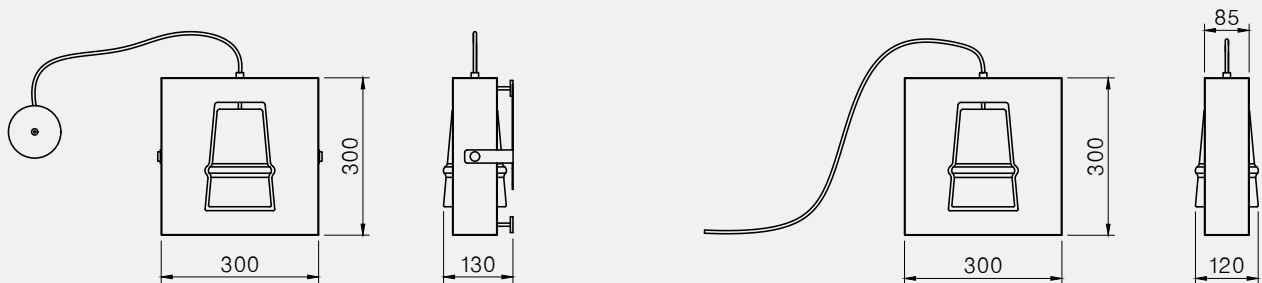

BELLE D'I 20 EMPREINTE AB60
 IP20 E14 G45 4w
 2700K 350lm

BELLE D'I 20 EMPREINTE PS01
 IP20 E14 G45 4w
 2700K 350lm



Belle d'I 20 ALM320





Belle d'I 20 ALM360
Hanging System : HS1-8



Belle d'1 20 ALM340
Belle d'1 20 ALM310
Belle d'1 20 ALM wall 91

Variations and finishes of
BELLE D'I 20 ALM



**BELLE D'I 20
ALM310**

**BELLE D'I 20
ALM320**

**BELLE D'I 20
ALM340**

**BELLE D'I 20
ALM360**



Black

Orange

Silver

Blue

Manufacturing & technical details of
BELLE D'I 20 ALM



Soft touch anodized aluminium.



Subtle light reflection and smooth curves.

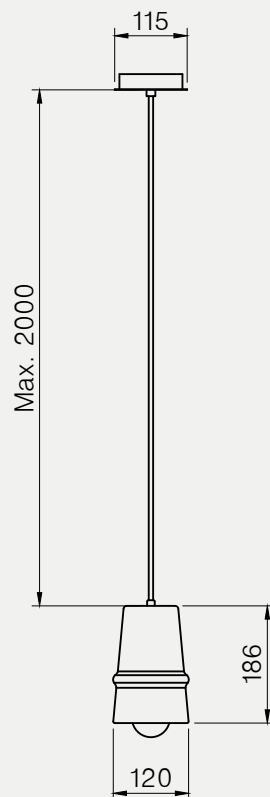

BELLE D'I 20 ALM
IP20 E27 GLS60 led 10w
2700K 810lm

Variations and finishes of
BELLE D'I 20 ALM WALL



**BELLE D'I 20
ALM WALL 91**

**BELLE D'I 20
ALM WALL 90**

**BELLE D'I 20
ALM WALL 93**

**BELLE D'I 20
ALM WALL 92**

Cap



Black



Orange



Silver



Blue

Structure



Matt
Black



White



Belle d'I 20 ALM WALL 91

Technical details of
BELLE D'I 20 ALM WALL

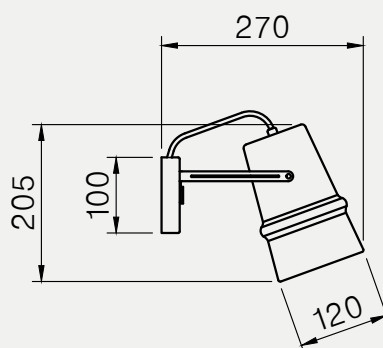

BELLE D'I 20 ALM WALL

IP20 E27 R80 led 4w
2700K 450lm



Belle d'I MTL20



Variations and finishes of
BELLE D'I MTL20

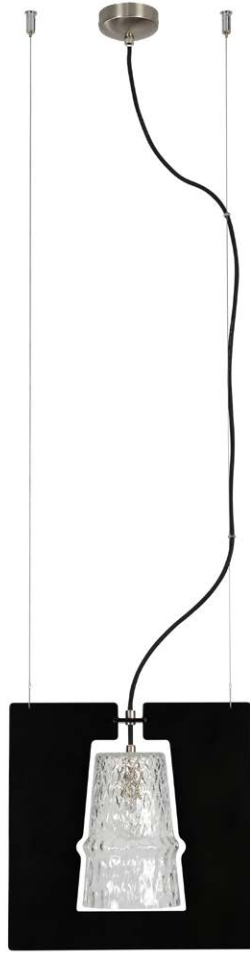

BELLE D'I MTL20

Cap



Cristal
glass

Structure



Black
coated steel

Manufacturing & technical details of
BELLE D'I MTL20

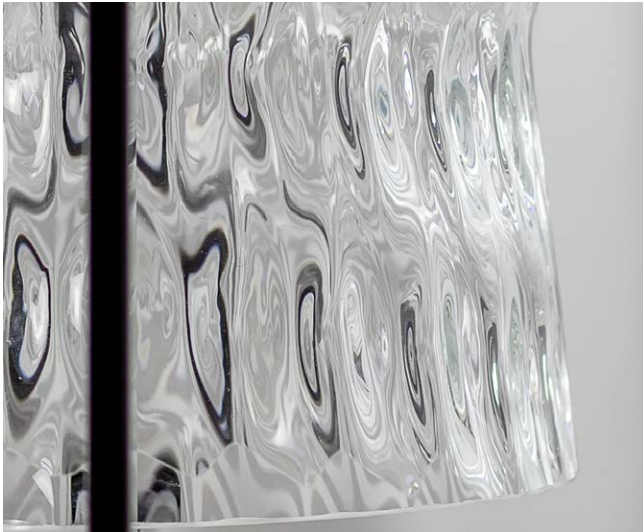

Cristal effect mouth blown glass.



Deep black ceramic coating.

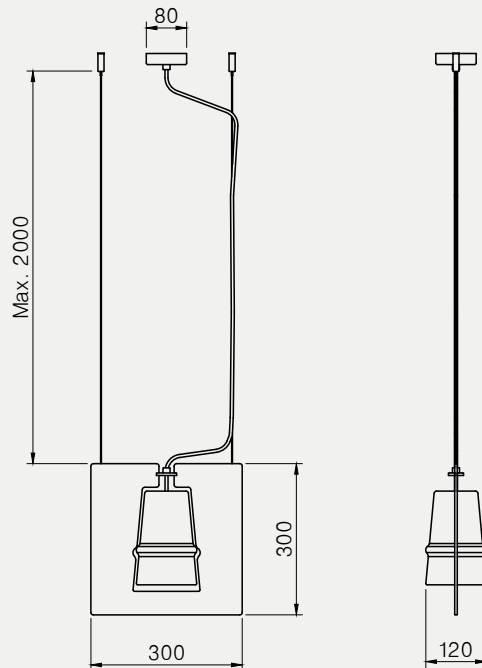

BELLE D'I MTL20
IP20 E14 G45 led 4w
2700K 320lm



Belle d'I 20 Chic 5020
Belle d'I 20 Chic 5010
Belle d'I 20 Chic 5030

Belle d'I 38 Tech 4000
Belle d'I 20 Tech Carbon



Variations and finishes of
BELLE D'I 20 CHIC & TECH



BELLE D'I 20
CHIC 5030 COPPER
CHIC 5040 SILVER
CHIC 5050 GOLD

BELLE D'I 20
CHIC 5010

BELLE D'I 20
CHIC 5020

BELLE D'I 20
TECH CARBON

BELLE D'I 20
TECH COPPER

Manufacturing & technical details of
BELLE D'I 20 CHIC & TECH



Handcrafted leaf on clear blown glass.



Precise slits for optimal light diffusion.

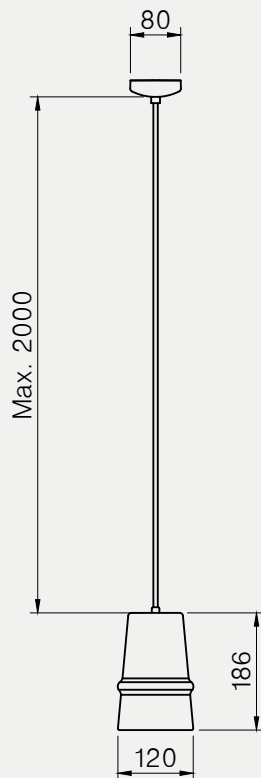

BELLE D'I 20 CHIC
IP20 E27 G45 led 4w
2700K 350lm

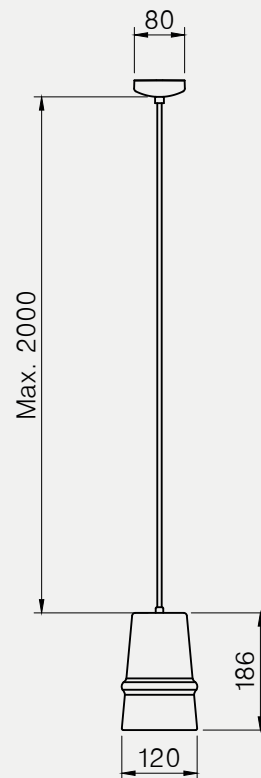

BELLE D'I 20 TECH
IP20 led module 8w
2700K 800lm

BELLE D'I 38

Design by Hind Rabii / 2015

For this collection, Hind Rabii drew her inspiration from the characteristic shape of Morocco's traditional Beldi glass for tea and infusions, featuring a central band in relief.

The simple, clean lines of the pendant are contrasted with the material quality of the glass, obtained by means of blow-moulding techniques.

Its central box supporting two light sources seems suspended in the air. A timeless lamp: stylish and original, it blends perfectly into any environment, whether classic or contemporary, to create a warm, evocative atmosphere.





Belle d'I 38 Chic 3080
Belle d'I 38 Chic 3070
Belle d'I 38 Chic 3060

Belle d'1 38 Chic 3050
Belle d'1 38 Chic 3070



Variations and finishes of
BELLE D'I 38 CHIC



**BELLE 38 CHIC
3060**



**BELLE 38 CHIC
3070**



**BELLE 38 CHIC
3080**



**BELLE 38 CHIC
3050**



**BELLE 38 CHIC
3090**



**BELLE 38 CHIC
3010**



**BELLE 38 CHIC
THE ONE**



**BELLE 38 CHIC
3030**



**BELLE 38 CHIC
3040**

Technical details of
BELLE D'I 38 CHIC

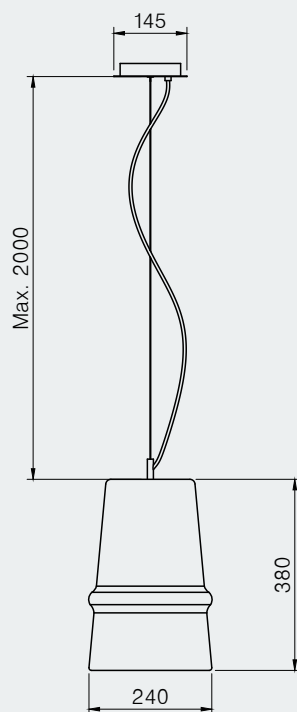

BELLE D'I 38 CHIC
IP20 E27 G125 led 5w
2500K 450lm



Belle d'1 38 Tech 4000



Belle d'I 38 Tech 4100
Belle d'I 20 Tech Copper







Belle d'1 38 Tech 4000

Variations and finishes of
BELLE D'I 38 TECH



**BELLE 38 TECH
4100**



**BELLE 38 TECH
4000**

Manufacturing & technical details of
BELLE D'I 38TECH



Perfect harmony between curves and technic.



Deep and soft reflecting surfaces.

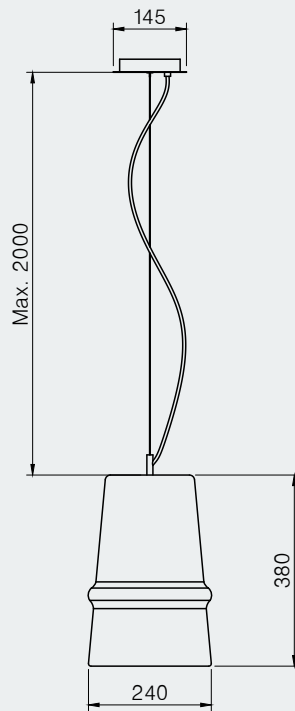

BELLE D'I 38 TECH
IP20 led module 10w
2700K 1000lm

OND'A

Design by Hind Rabii / 2018

Like a flying UFO, Ond'a is of a fluid and airy simplicity while being precious by its materials and the artisanal work of its finishes.



Ond'A White & Gold

Ond'A Vestita





Variations and finishes of **OND'A**



**OND'A L
BLACK & GOLD**

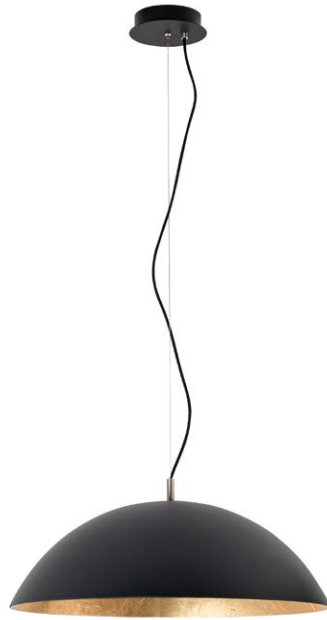

**OND'A S
BLACK & GOLD**



**OND'A VESTITA
WHITE & GOLD**

Outer finish



Matt White

Matt Black

Inner finish



Gold Leaf

Silver Leaf

Copper Leaf

Schade



Insolence



Extrat matt stuctured finish and handcrafted leaf.



Light diffuser for invisible source.

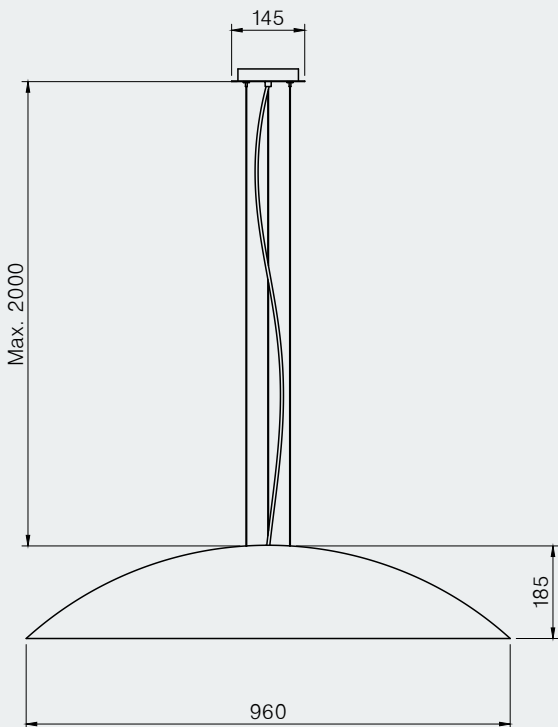

OND'A L
IP20 Led module 25w
2700K 3000lm

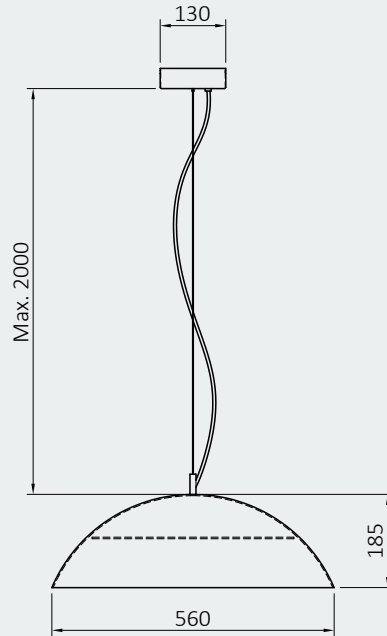

OND'A S
IP20 Led module 17w
2700K 2200lm

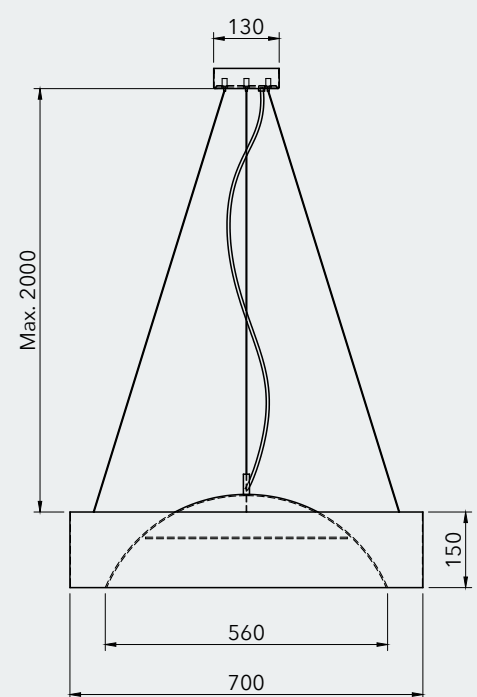

OND'A VESTITA
IP20 Led module 17w
2700K 2200lm

ANNETTE & LUBIN

Design by Jean François d'Or / 2016

Annette and Lubin are two characters from a tale written by Jean-François Marmontel in 1761, telling the true story of Marie Schmitz and Gilles Dewalt of Spa. In their lifetime this couple would become Annette and Lubin of Spa, lending their name to the luscious green hill at the top of which they lived.

Celebrated and remembered by this town, Queen of the Belgian Ardennes, placed in this oasis, this region of springs.

Annette and Lubin is a collection of lights inspired by this region and these two characters. Where the sphere and cone meet, superimposed blown glass and locally sourced oak; the freshness of undergrowth and a July morning, with pearl pink on the leaves of a lush green colour palette.

Versatile blends of these two geometric shapes that stem from the intersections of materials and colours of Annette and Lubin.



Annette & Lubin ALB99
Annette & Lubin ALB02
Annette & Lubin ALB30



Annette & Lubin ALB70
Annette & Lubin ALB40



Variations and finishes of
ANNETTE & LUBIN



**ANNETTE&LUBIN
ALB02**

**ANNETTE&LUBIN
ALB99**

**ANNETTE&LUBIN
ALB89**



**ANNETTE&LUBIN
ALB30**

**ANNETTE&LUBIN
ALB71**

**ANNETTE&LUBIN
ALB41**

Manufacturing & technical details of
ANNETTE & LUBIN



Play of transparency between glass and wood.



Solid oak shape.

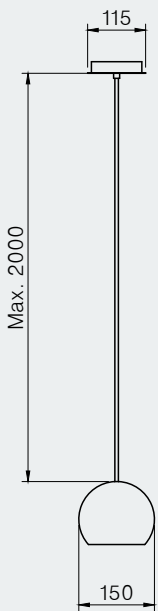

ALB02
 IP20 E27 R80 led 4w
 2700K 450lm

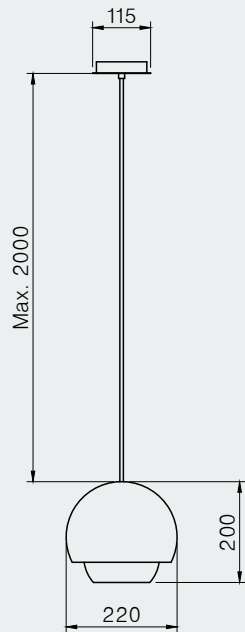

ALB99
 IP20 E27 R80 led 4w
 2700K 450lm

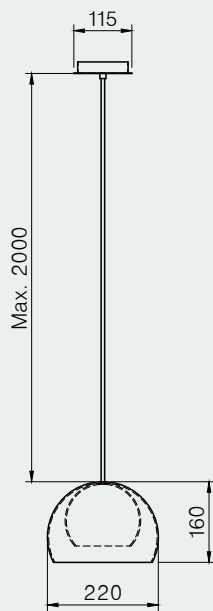

ALB89
 IP20 E14 G45 led 4w
 2700K 350lm

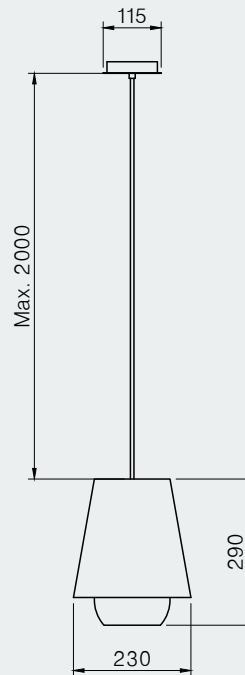

ALB30 - ALB71
 IP20 E14 G45 led 4w
 2700K 350lm

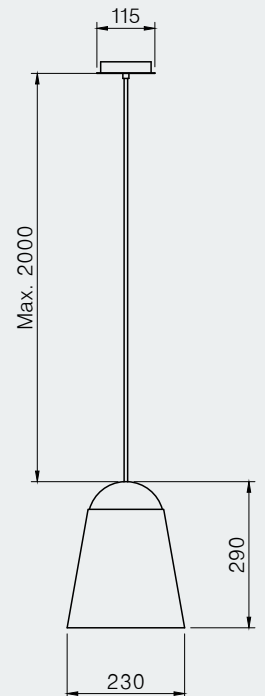

ALB41
 IP20 E27 GLS60 led 10w
 2700K 810lm

VOLTE - FACE

Design by Hind Rabii - Maxim Pien / 2017

Lights reach us from above. The sun and the moon, eternal accomplices, rise and set early to illuminate our days and stimulate our nights. And the lights from below boil down to, in such concentration, volcanoes that exult the incandescence of the earth, from far, far away.

What violence, what unimaginable beauty, all these rays, direct and indirect.

We want to VOLTE FACE to play with all these interactions, reflections, direct and indirect rays, rays from above, rays from below, brightness, colours.

EVERYWHERE, VOLTE FACE, EVERYWHERE.



Volte - Face VLT10 Gold



Volte - Face VLT200 Gold



Volte³ - Face VLT200 Gold

Variations and finishes of VOLTE - FACE



**VOLTE-FACE
VLT10**

**VOLTE-FACE
VLT200**

Inner finish

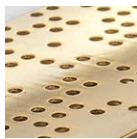

Shiny
Gold



Shiny
Nickel

Electrical cord

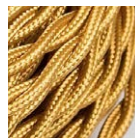

Gold



Black

Manufacturing & technical details of **VOLTE - FACE**



Precious details of inner part.



Subtle transparency of acrylic glass.

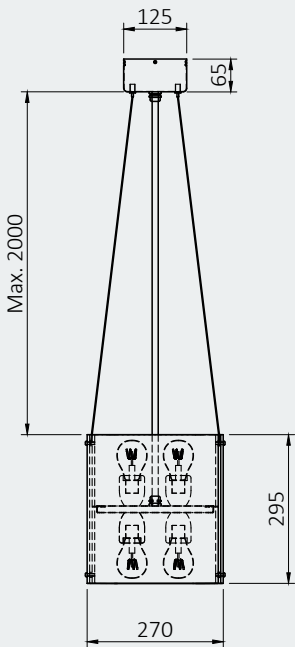

VLT10
IP20 E27 G60 led 4x5w
2700K 1800lm

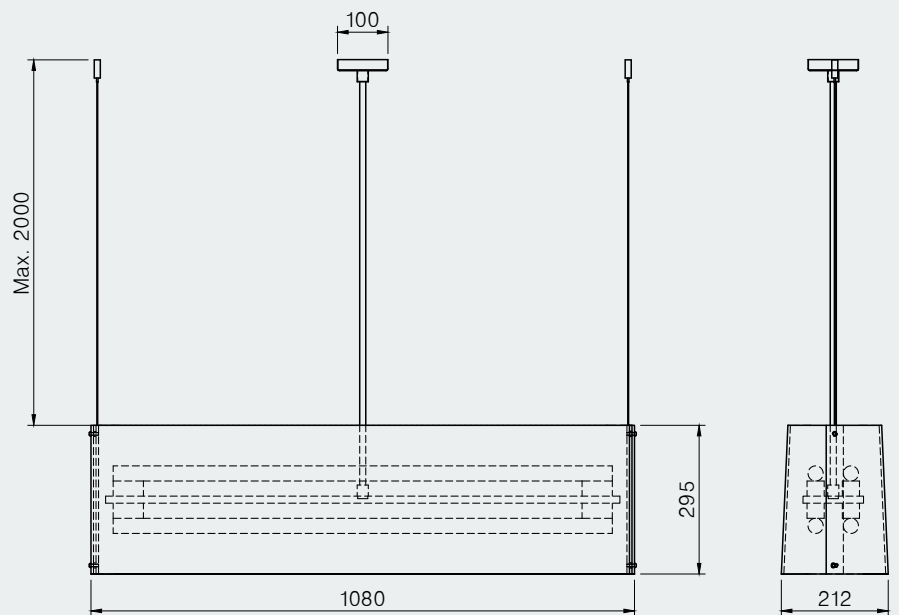

VLT200
IP20 S14s led tube 4x17w
2700K 4600lm

LET ME READ

Design by Hind Rabii / 2018

Let Me Read is a concept.

*Combination of wall lamp and hanging light,
a play of different colors and a mix of two
functions.*

*Free of limits, free of space, the suspension may
take place anywhere.*



*Let Me Read LMR02-50 White
with Ice pendant.*

Variations and finishes of LET ME READ



LMR01-50
WHITE



LMR01-50
BLACK



LMR02-50
WHITE

Wall bracket finish



Matt
White

Matt
Black

Flexible tube finish

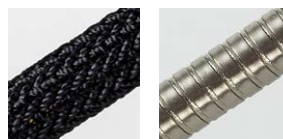

Black
cord

Stainless
steel

* see page 50 for Ice cap available finishes.



Let Me Read LMR01-50 Black
Let Me Read LMR01-50 White

Technical details of LET ME READ

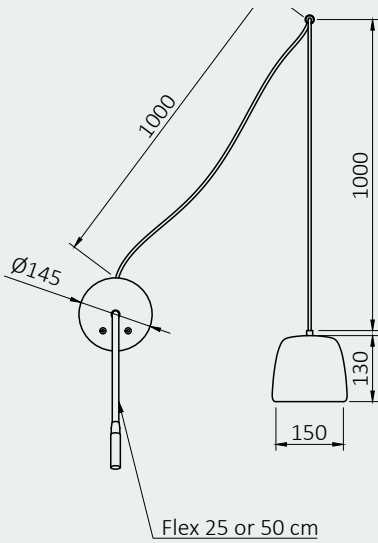

LMR02-25
LMR02-50

IP20 Powered 3w + lens 2700K (flex)
Led module 8w 2700K 800lm (cap)

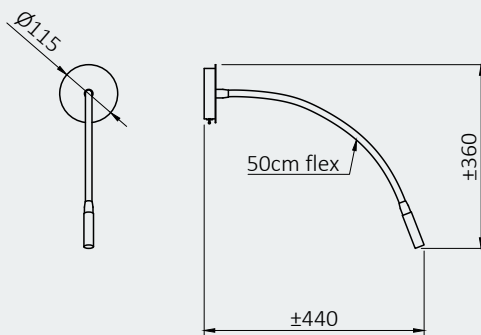

LMR01-50

IP20 Powered 3w + lens 2700K (flex)

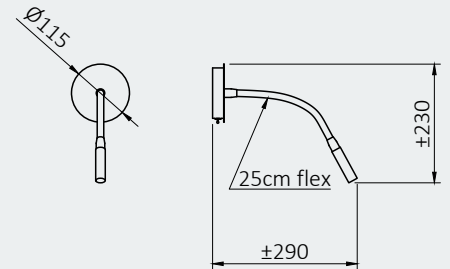

LMR01-25

IP20 Powered 3w + lens 2700K (flex)

Copyright HIND RABII 2020 ©

Design - graphics - scenography : Hind Rabii and Michel Orban

Photos :

Michel Orban

Serge Anton

Luc Viatour

Special thanks to Ludivine Gaildry - Art Director.



FSC Cover printed on 100% recycled paper.