

oluce Milano dal 1945

MILANO, DAL 1945

Fondata nel 1945, Oluce rappresenta la più storica azienda italiana di design ancora attiva nel campo dell'illuminazione. L'azienda è stata infatti in grado di costruire negli anni una collezione strutturata come un racconto, abitato da prodotti capaci di superare le mode per divenire icone del design italiano. Già presente alla IX triennale di Milano, nel corso della sua lunga storia Oluce ha ricevuto numerosi riconoscimenti, tra cui due Compassi d'Oro, due Design Award e la Medaglia d'Oro alla XIII Triennale di Milano. Le sue lampade compaiono nelle più importanti collezioni permanenti di design del mondo.

Founded in 1945, Oluce represents the oldest Italian design company in the lighting field still active, a symbol of a reality that withstood the test of time. Over the years, the company has been able to create a collection structured as if it were a story, with products capable of surpassing trends to become icons of Italian design. Oluce, already present at the 9th Triennale in Milan, throughout its long history has received numerous acknowledgements, including two Golden Compass awards, two Design Awards and the Gold Medal at the 13th Triennale in Milan. Its lamps take pride of place in the most important permanent design collections worldwide.





EXPERIENCE

L'esperienza di Oluce rivela un'eccellenza produttiva unica che traduce in forme un'appassionata ricerca tecnologica sulle potenzialità della luce, di cui ogni lampada costituisce una tappa. Materiali inconsueti, forme inedite e nuove fonti luminose hanno dato vita nel tempo a progetti rivoluzionari firmati da Tito Agnoli, Joe Colombo, Marco Zanuso e Vico Magistretti che dagli anni '50 hanno riscritto la storia dell'illuminazione. Le collezioni recenti confermano lo spirito progettuale e decorativo dei prodotti di Oluce, interpretato dalle linee di designer italiani e internazionali come Angeletti&Ruzza, Francesco Rota, Astori/De Ponti, Nendo, Victor Vasilev, Nicola Gallizia, Christophe Pillet e Mist-o

Oluce experience reveals a unique manufacturing excellence that translates keen technological research of lighting potential into shape, of which each lamp represents a stage. Over time, unusual materials, unprecedented shapes and new light sources have given life to revolutionary projects designed by Tito Agnoli, Joe Colombo, Marco Zanuso and Vico Magistretti who have contributed to the rewriting of the history of lighting since the 1950s. The most recent collections confirm the design and decorative spirit of Oluce's products, interpreted by the signs of Italian and international designers such as Angeletti&Ruzza, Francesco Rota, Astori/De Ponti, Nendo, Victor Vasilev, Nicola Gallizia, Christophe Pillet and Mist-o

BESPOKE TAILORING

L'esperienza tecnica dell'azienda e il suo legame con il mondo del progetto hanno dato vita in tempi recenti al Bespoke Tailoring, una speciale sezione dedicata al contract. Il Bespoke Tailoring si configura come un servizio di "personalizzazione prodotto" pensato appositamente per questo genere di realizzazioni. Oltre alla proposta disponibile a catalogo, infatti, l'azienda offre la possibilità di realizzare lampade su misura per esigenze specifiche oppure di produrre varianti modulabili di prodotti a collezione già esistenti.

The company technical knowledge and its bond with the project world have recently resulted in the establishment of the Bespoke Tailoring service, a special section dedicated to contract solutions. Bespoke Tailoring is considered a "product personalisation" service, especially designed for this type of creations. In addition to the products that are available in the catalogue, the company offers the possibility to create bespoke lamps to fulfil specific needs or to produce adaptable versions of products from existing collections.



SPACES

Grazie alla loro potenza espressiva, prodotti a catalogo e varianti personalizzate sono stati scelti nel tempo da architetti e progettisti di tutto il mondo per caratterizzare ambienti preziosi e ricercati. Oluce compare, tra gli altri, all'interno di progetti come il Room Mate Giulia Hotel, firmato da Patricia Urquiola, il MeMilan "Il Duca", di Arassociati Studio di Architettura con Alvaro Sans e Nicola Gallizia e nell'ultimo albergo della catena Roomers a Baden Baden progettato da Lissoni Architettura con KHP architekten.

Thanks to their visual potential, both products in the catalogue and personalized variations have been chosen over time by international architects and designers to characterize polished and refined locations. Among others you can find Oluce in projects such as Room Mate Giulia Hotel by Patricia Urquiola, MeMilan "Il Duca", by Arassociati Studio di Architettura with Alvaro Sans and Nicola Gallizia and in the last hotel of the chain Roomers in Baden Baden designed by Lissoni Architettura with KHP architekten.

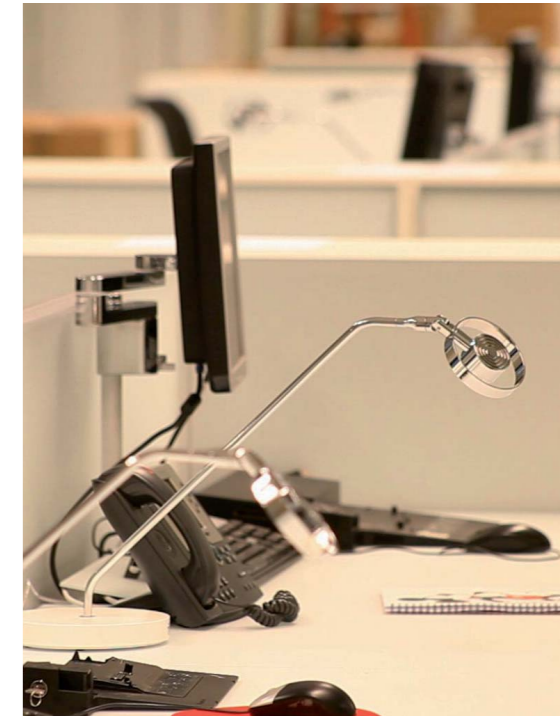





ABACO / ABACUS

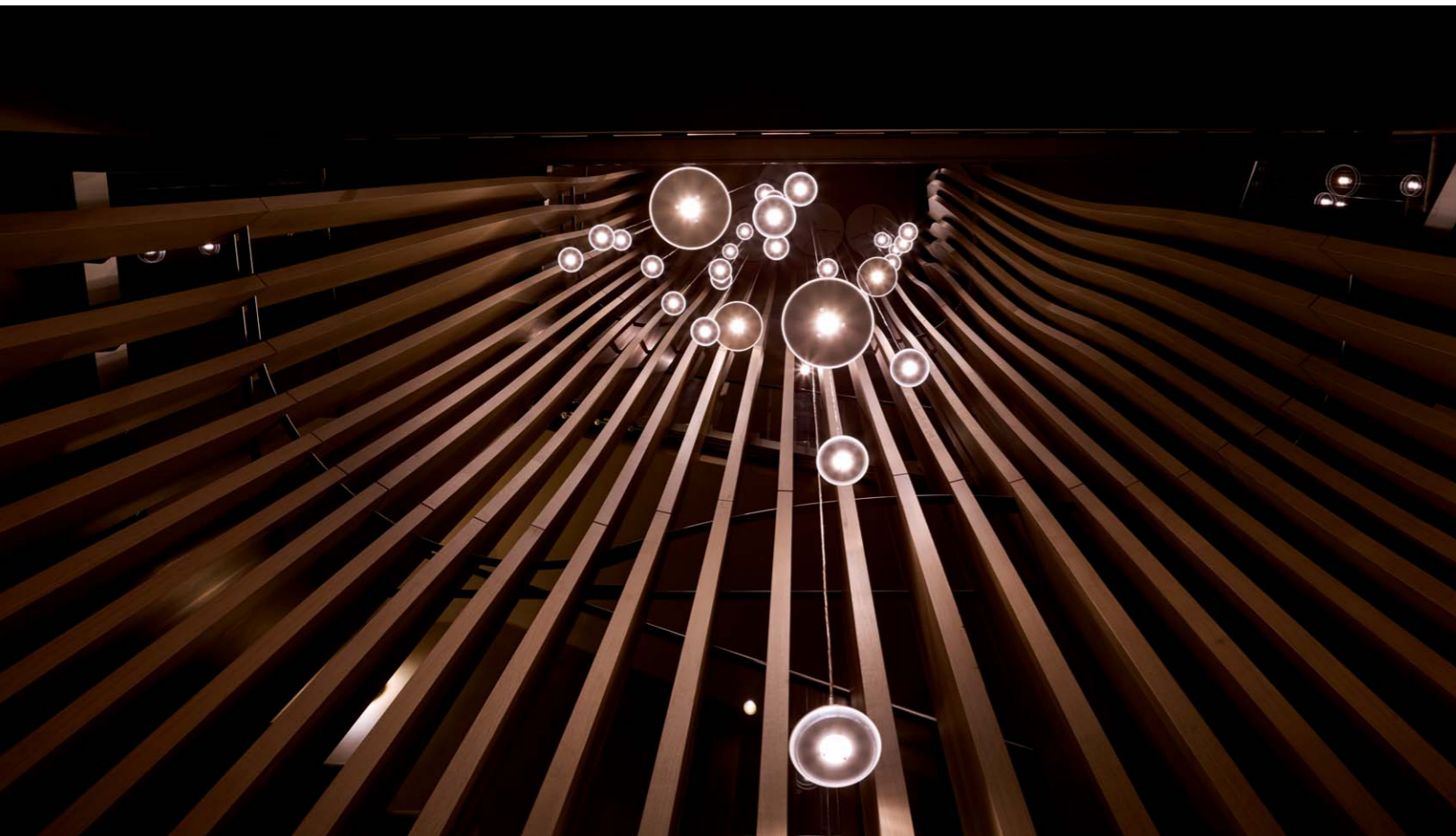

ABACO / ABACUS

LAMPADE DA TAVOLO / TABLE LAMPS



Alba 20-21 **Eva** 34-35 **Recuerdo** 36-37 **Cylinda** 44-45 **Plume** 52-53 **Atollo** 62-69 **Superluna** 70-71 **The Globe** 72-73 **Duca** 74-75 **Zanuso** 76-79 **Semplice** 80-83

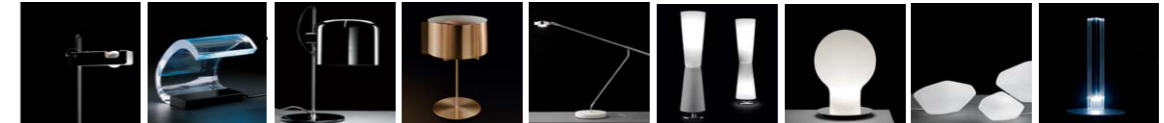

Spider 84-85 **Acrilica** 86-87 **Coupé** 88-89 **Switch** 90-93 **Lutz** 94-97 **Lu-Lu** 98-99 **Denq** 100-101 **Stone of glass Cand Led** 102-103 104-105

LAMPADE DA TERRA / FLOOR LAMPS



Alba 22-25 **Coupé** 58-59 **Las** 108-111 **Superluna** 112-115 **Coupé** 120-123 **Coupé** 124-127 **Spider** 118-119 **Agnoli** 128-129 **Pascal** 116-117 **Lu-Lu** 130-131 **Switch** 132-133



Do with 134-137 **Colombo** 138-139 **Dim** 140-141

LAMPADE DA PARETE-SOFFITTO / WALL - CEILING LAMPS

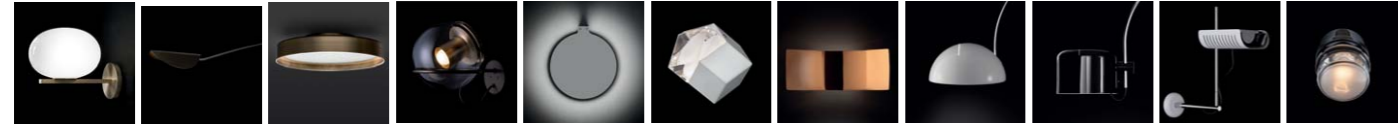

Alba 26-29 **Plume** 54-57 **Berlin** 40-43 **The Globe** 144-145 **Duca** 146-149 **Astro** 150-151 **Lens** 152-155 **Coupè** 156-157 **Coupè** 158-159 **Colombo** 160-161 **Fresnel** 162-163



Voilà 164-165 **Yolk** 166-167 **Kelly** 168-169 **Fiore** 170-171 **Line** 172-173 **JK** 174-175 **Lyndon** 176-177 **Sixty** 178-179

LAMPADE A SOSPENSIONE / SUSPENSION LAMPS



Alba 30-31 **Recuerdo** 38-39 **Niwa** 46-49 **Lyndon** 50-51 **The Globe** 182-185 **Kin** 186-189 **Lys** 190-193 **Empty** 194-197 **Sonora** 198-199 **Sonora** 200-203 **Sonora** 204-207



Canopy 208-211 **Colombo** 212-213 **Plateau** 214-215 **Coroa** 216-217 **Circles** 218-221 **Fiore** 222-225 **Lanterna** 226-229

LAMPADE DA ESTERNO / OUTSIDE LAMPS



Stones 232-233 **Lyndon** 234-237 **Lyndon** 238-239 **Fresnel** 240-241 **Fresnel** 242-243 **Pill-low** 244-247

NUOVA COLLEZIONE / NEW COLLECTION

- ALBA
- BERLIN
- COUPÉ
- CYLINDA
- EVA
- LYNDON
- NIWA
- PLUME
- RECUERDO

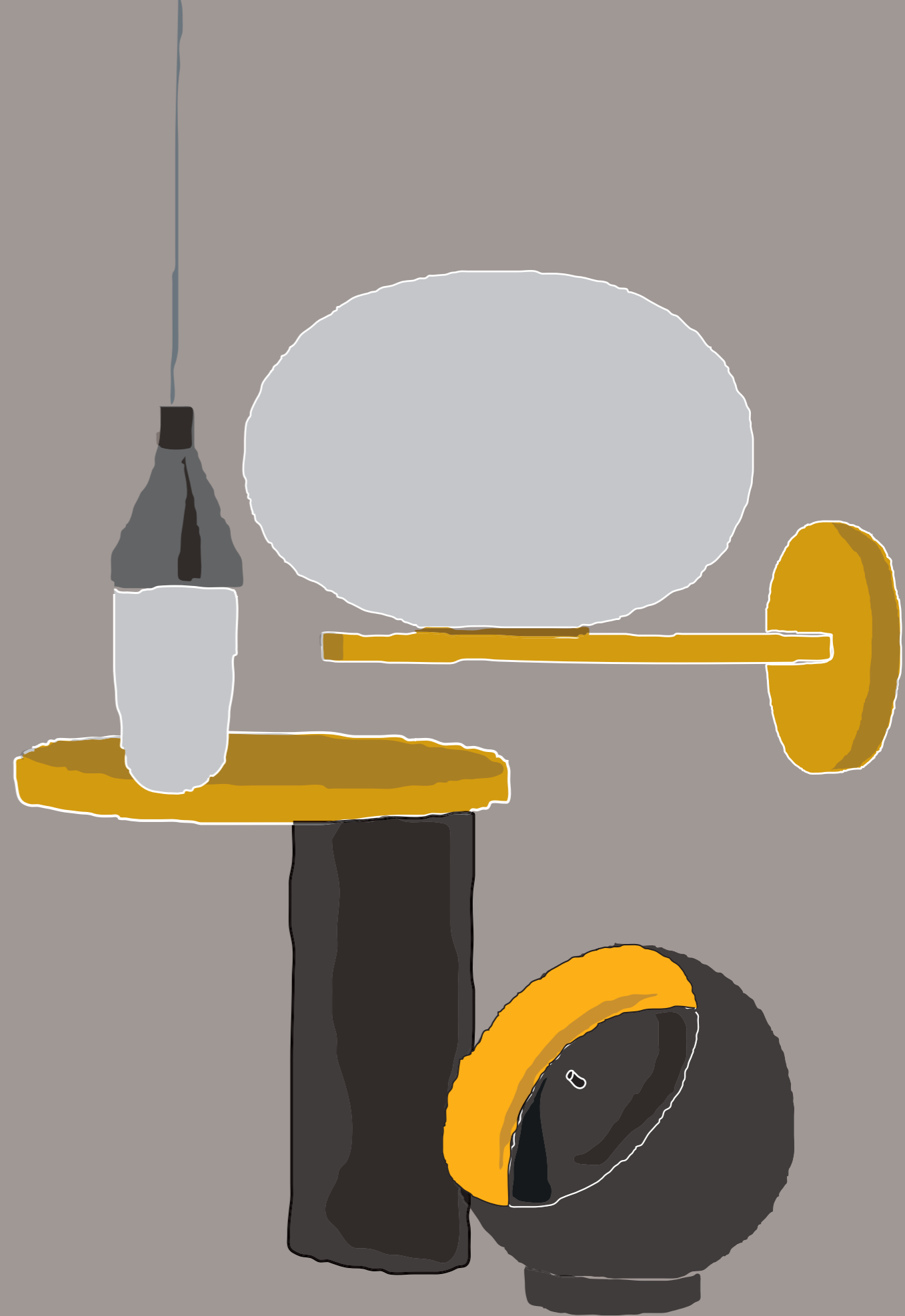

NEW COLLECTION



Alba
20-21



Alba
22-25



Berlin
40-41



Berlin
42-43



Cylinda
44-45



Alba
26-29



Alba
30-33



Niwa
46-49



Lyndon
50-51



Eva
34-35



Recuerdo
36-37



Recuerdo
38-39



Plume
52-53



Plume
54-57



Coupé
58-59



ALBA
Mariana
Pellegrino Soto
2017



265

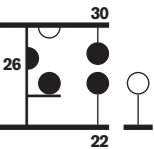
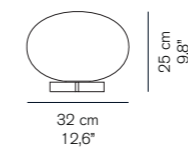

CODICE/CODE	SORGENTI/BULBS	MATERIALI/MATERIALS	COLORE/COLORS	MARCHI/MARKS
265 (universal dimmer)	 1 x max 60 W o/or 15 W (LED)  E27	metallo / vetro soffiato metal / blown-glass	ottone satinato / opale lucido satin brass / polished opaline	



ALBA

Mariana
Pellegrino Soto
2017



382

383

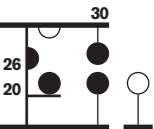
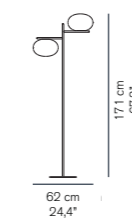

CODICE/CODE	SORGENTI/BULBS	MATERIALI/MATERIALS	COLORE/COLORS	MARCHI/MARKS
382 (universal dimmer)	1 x max 60 W o/ or 15 W (LED) E27	metallo /vetro soffiato metal / blown-glass	ottone satinato /opale lucido satin brass/polished opaline	CE
383 (universal dimmer)	2 x max 60 W o/ or 15 W (LED) E27	metallo /vetro soffiato metal / blown-glass	ottone satinato /opale lucido satin brass/polished opaline	CE





ALBA
Mariana
Pellegrino Soto
2017



176

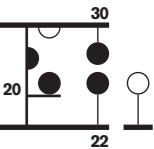
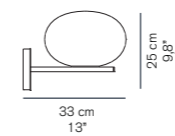

CODICE/CODE	SORGENTI/BULBS	MATERIALI/MATERIALS	COLORE/COLORS	MARCHI/MARKS
176	 1 x max 60 W  E27	metallo / vetro soffiato metal / blown-glass	ottone satinato / opale lucido satin brass / polished opaline	



ALBA

Mariana
Pellegrino Soto
2017





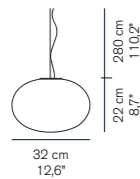

465

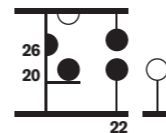
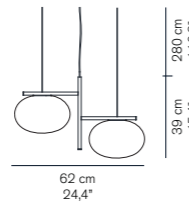

468



CODICE/CODE	SORGENTI/BULBS	MATERIALI/MATERIALS	COLORE/COLORS	MARCHI/MARKS
465	 1 x max 60 W  E27	metallo/vetro soffiato metal/blown-glass	ottone satinato/opale lucido satin brass/polished opaline	CE
468	 2 x max 60 W  E27	metallo/vetro soffiato metal/blown-glass	ottone satinato/opale lucido satin brass/polished opaline	CE







EVA
 Francesca Borelli
 2017



216

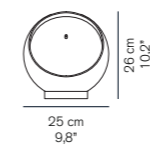

CODICE/CODE	SORGENTI/BULBS	MATERIALI/MATERIALS	COLORE/COLORS	MARCHI/MARKS
216	 1 x max 15W LED	metallo metal	esterno nero-interno oro black outside-gold inside	

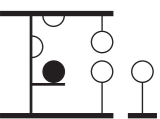





RECUERDO

Mariana Pellegrino Soto
2017

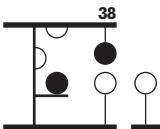

284



CODICE/CODE	SORGENTI/BULBS	MATERIALI/MATERIALS	COLORE/COLORS	MARCHI/MARKS
284	 1 x max 12 W LED 220 V	vetro soffiato/alluminio blown-glass/aluminium	trasparente/alluminio anodico transparent/anodic aluminium	





RECUERDO

Mariana
Pellegrino Soto
2017

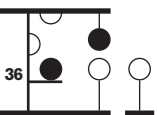
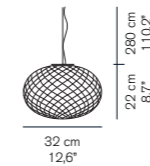

484



CODICE/CODE	SORGENTI/BULBS	MATERIALI/MATERIALS	COLORE/COLORS	MARCHI/MARKS
484	 1 x max 12 W LED 220 V	vetro soffiato/alluminio blown-glass/aluminium	trasparente/alluminio anodico transparent/anodic aluminium	

BERLIN

Christophe Pillet
2017



720

721

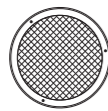

30 cm
11,8"

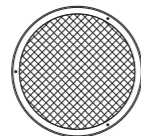

40 cm
15,7"

40 cm
15,7"



CODICE/CODE	SORGENTI/BULBS	MATERIALI/MATERIALS	COLORE/COLORS	MARCHI/MARKS
720	2 x max 10W E14 LED	metallo/vetro retinato sabbiato metal/sand-blasted wired glass	oro satinato satin gold	CE
721	2 x max 15W E27 LED	metallo/vetro retinato sabbiato metal/sand-blasted wired glass	oro satinato satin gold	CE



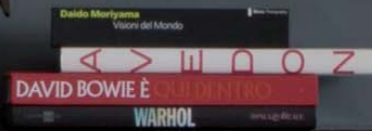
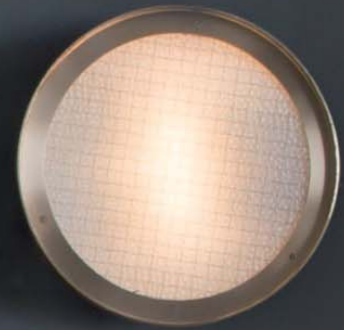
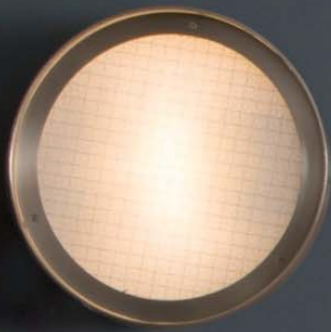

CYLINDRA

Angeletti & Ruzza
2017



218

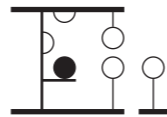
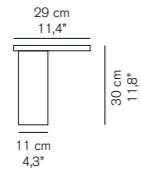

CODICE/CODE	SORGENTI/BULBS	MATERIALI/MATERIALS	COLORE/COLORS	MARCHI/MARKS
218	1 x max 15 W LED	metallo /metal	nero opaco/ nero opaco - oro satinato nero opaco/matt black - satin gold	CE





NIWA
Christophe Pillet
2017



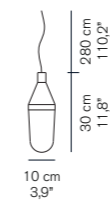

1180

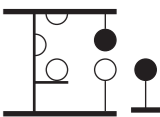
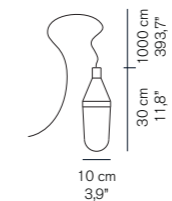

1182



CODICE/CODE	SORGENTI/BULBS	MATERIALI/MATERIALS	COLORE/COLORS	MARCHI/MARKS
1180	 1 x max 15 W E27 LED	alluminio/vetro aluminium/glass	grigio beige beige grey	CE
1182	 1 x max 15 W E27 LED	alluminio/vetro aluminium/glass	grigio beige beige grey	CE IP44







LYNDON
Vico Magistretti
1977

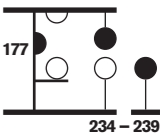
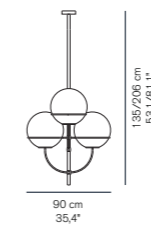

450



CODICE/CODE	SORGENTI/BULBS	MATERIALI/MATERIALS	COLORE/COLORS	MARCHI/MARKS
450	 4 x max 100 W  E27	metallo/vetro metal/glass	cromato / trasparente chromium-plated / transparent	

PLUME

Christophe Pillet
2017



221

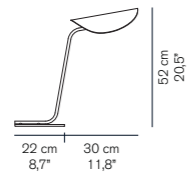

CODICE/CODE	SORGENTI/BULBS	MATERIALI/MATERIALS	COLORE/COLORS	MARCHI/MARKS
221	 1 x max 40W E14	metallo metal	anodic bronzo anodic bronze	









PLUME
Christophe Pillet
2017

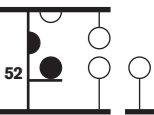
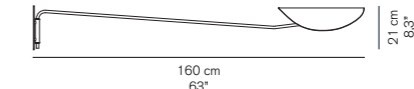
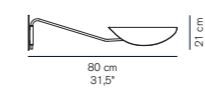

158

159



CODICE/CODE	SORGENTI/BULBS	MATERIALI/MATERIALS	COLORE/COLORS	MARCHI/MARKS
158	 1 x max 40W E14	metallo metal	anodico bronzo anodic bronze	
159	 1 x max 60W E27	metallo metal	anodico bronzo anodic bronze	







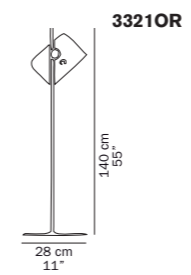
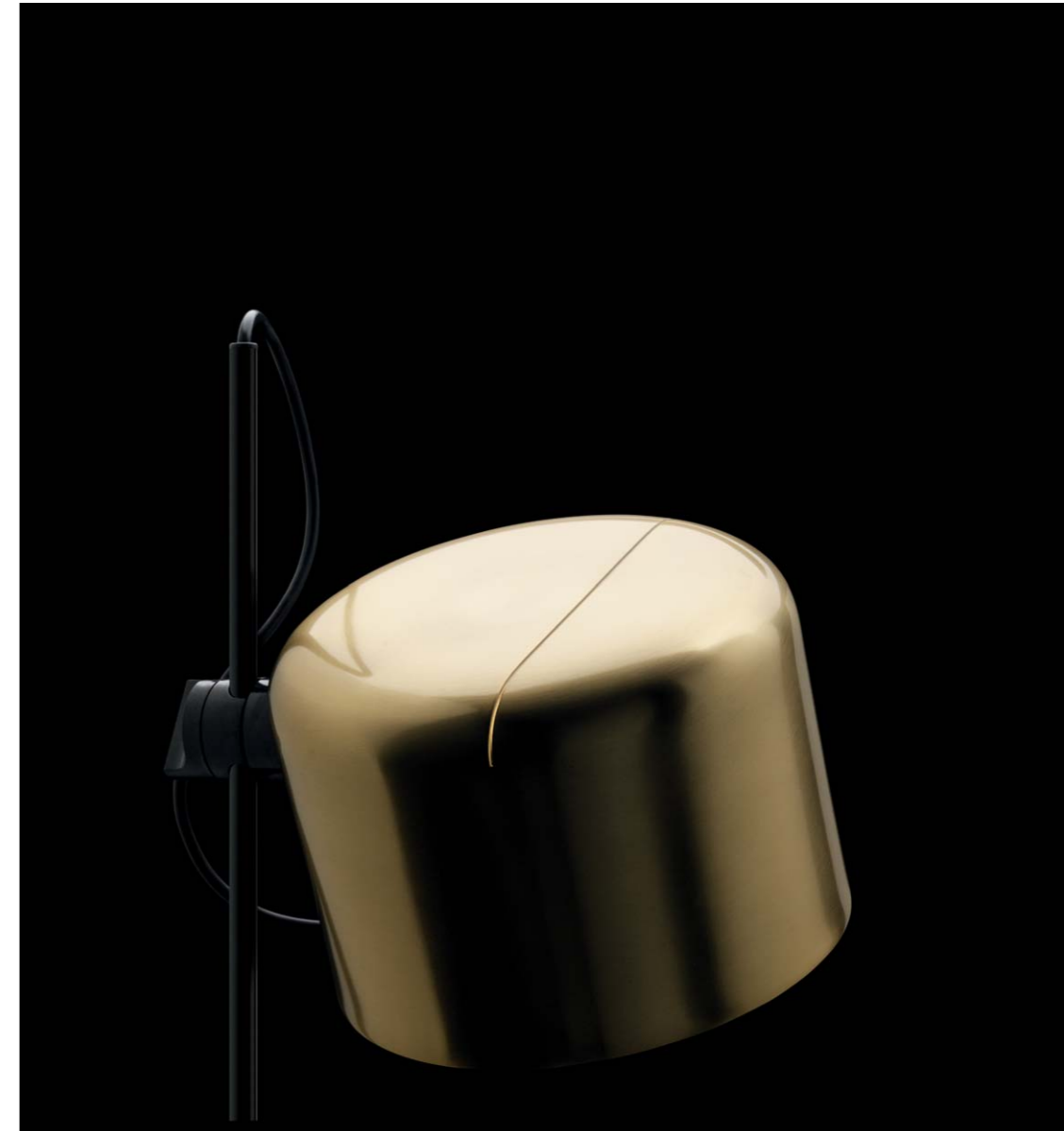

COUPÈ
(Limited Edition)
Joe Colombo
1967

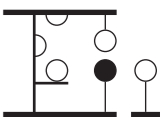

pagine/ pages



CODICE/CODE	SORGENTI/BULBS	MATERIALI/MATERIALS	COLORE/COLORS	MARCHI/MARKS
3321 OR	 1 x max 100 W E27	metallo/alluminio metal/aluminium	oro - nickel nero gold - black nickel	  

LAMPADE DA TAVOLO / TABLE LAMPS

ACRILICA

AGNOLI

ASTRO

ATOLLO

CAND-LED

CANOPY

CIRCLES

COLOMBO

COROA

COUPÉ

DENO

DIM

DO WITH

DUCA

EMPTY

FIORE

FRESNEL

JK

KELLY

KIN

LANTERNA

LANTERNINA

LAS

LENS

LINE

LU-LU

LUTZ

LYNDON

LYS

PASCAL

PILL-LOW

PLATEAU

SEMPLICE

SIXTY

SONORA

SPIDER

STONE OF GLASS

STONE

SUPERLUNA

SWITCH

THE GLOBE

VOILÀ

YOLK

ZANUSO

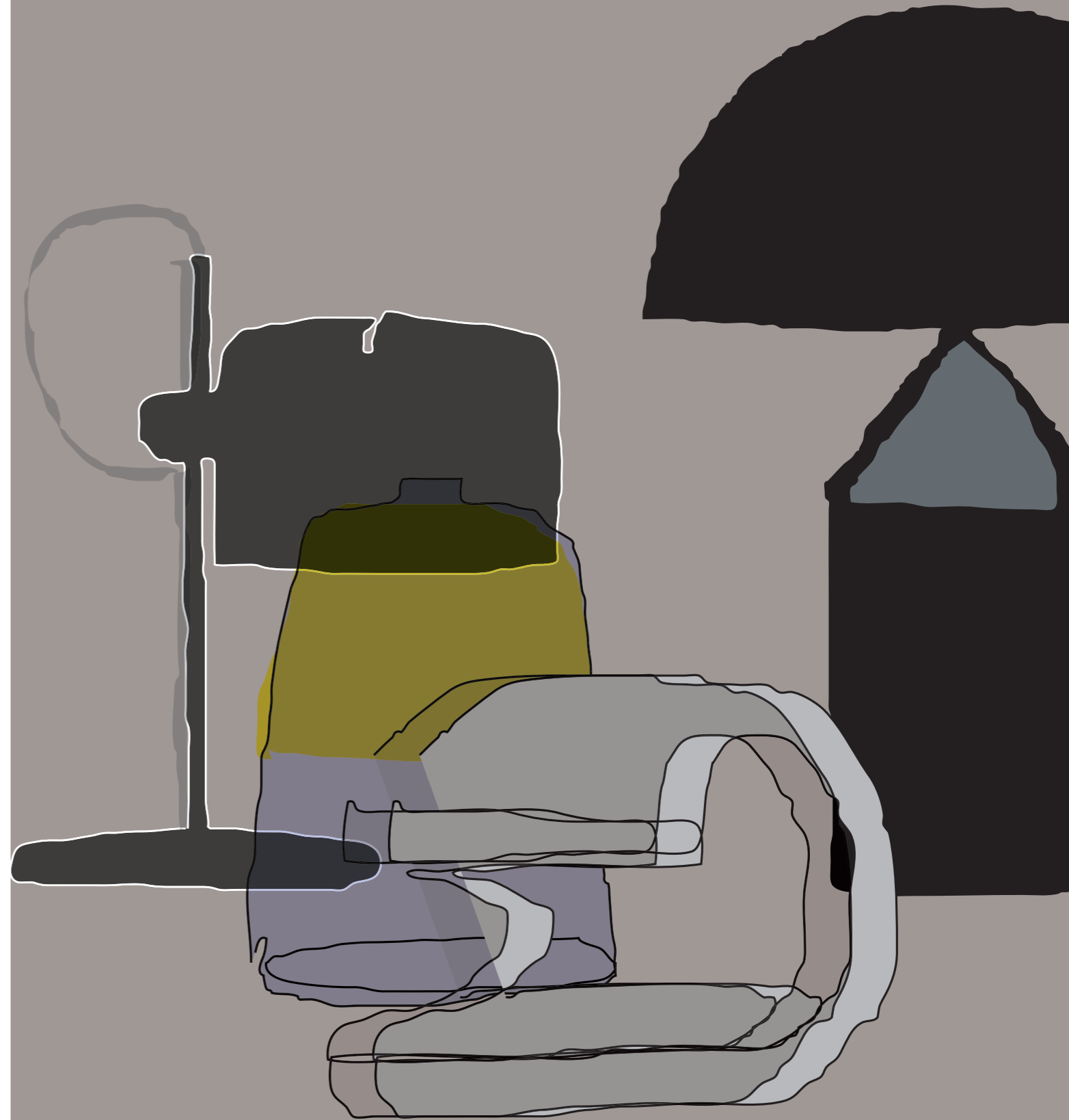

ATOLLO

Vico Magistretti
1977



235

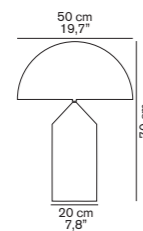

236

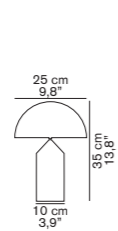

237

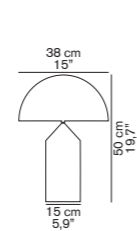

pagine/ pages

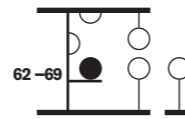

CODICE/CODE	SORGENTI/BULBS	MATERIALI/MATERIALS	COLORE/COLORS	MARCHI/MARKS
235 (dimmer)	2 x max 100 W – 2 x max 25 W E27 E14	metallo/vetro soffiato metal/blow glass	opale acidato opaline opaque	CE UL CCC
236	2 x max 40 W – 1 x max 25 W E14	metallo/vetro soffiato metal/blow glass	opale acidato opaline opaque	CE UL CCC
237 (dimmer)	2 x max 75 W – 1 x max 40 W E27 E14	metallo/vetro soffiato metal/blow glass	opale acidato opaline opaque	CE UL CCC





A black leather chair with a tufted backrest and a geometric patterned cushion. The chair is positioned near a large window, providing a view of a lush green forest. The chair's design is modern and functional, with a metal frame and a leather seat.

A glowing mushroom-shaped lamp with a white, dome-shaped shade and a white, cylindrical base. The lamp is placed on a small, dark, round side table. The light it emits is warm and soft, creating a cozy atmosphere.

A glowing mushroom-shaped lamp with a white, dome-shaped shade and a white, cylindrical base. The lamp is placed on the floor, and its light is warm and soft, creating a cozy atmosphere.

A glowing mushroom-shaped lamp with a white, dome-shaped shade and a white, cylindrical base. The lamp is placed on the floor, and its light is warm and soft, creating a cozy atmosphere.

A low, dark coffee table with a brass tray on top. The table is positioned in the foreground, and it holds several books and magazines. The books are stacked neatly, and the magazines are fanned out. The table's design is simple and functional, with a dark finish and a brass tray.

A small, rectangular opening in the concrete wall, serving as a fireplace. It is filled with a stack of logs, ready for a fire. The opening is set into the wall, and the logs are stacked neatly, creating a warm and inviting focal point.



ATOLLO
Vico Magistretti
1977



233

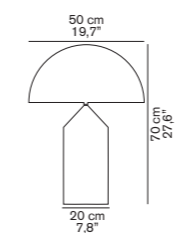

238

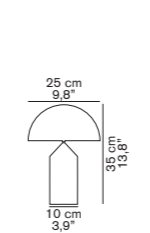

239

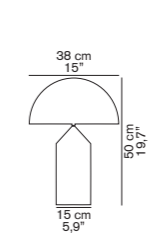

pagine/pages



CODICE/CODE	SORGENTI/BULBS	MATERIALI/MATERIALS	COLORE/COLORS	MARCHI/MARKS
233 (dimmer)	✱ 2 x max 100 W E27	metallo metal	bianco/nero/oro white/black/gold	CE (V) CCC
238	✱ 2 x max 40 W E14	metallo metal	nero/oro black/gold	CE (V) CCC
239 (dimmer)	✱ 2 x max 75 W E27	metallo metal	nero/oro black/gold	CE (V) CCC



SUPERLUNAVictor Vasilev
2015

297

pagine/pages

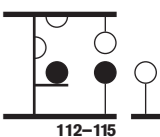
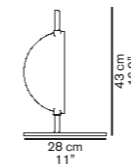
**CODICE/CODE**

297

SORGENTI/BULBS
 1 x max 7,5 W
LED 24 V
MATERIALI/MATERIALSmetallo
metal**COLORE/COLORS**ottone – asta nera / nero – asta nera
brass – black stem / black – black stem**MARCHI/MARKS**

THE GLOBE



Joe Colombo
1964

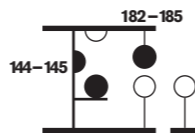
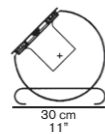

228

pagine/pages



CODICE/CODE	SORGENTI/BULBS	MATERIALI/MATERIALS	COLORE/COLORS	MARCHI/MARKS
228	 1 x max 60 W E27	metallo/ vetro soffiato metal/blow glass	nickel satinato - oro satinato/anodic bronzo satin nickel - satin gold/anodic bronze	 



DUCA

Nicola Gallizia
2015



2950

pagine/ pages

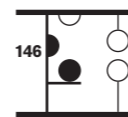
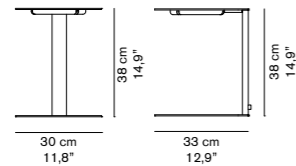

CODICE/CODE	SORGENTI/BULBS	MATERIALI/MATERIALS	COLORE/COLORS	MARCHI/MARKS
2950	1 x max 14 WLED 220V	metallo metal	grigio caldo warm grey	CE



ZANUSO



Marco Zanuso
1965

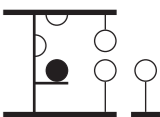
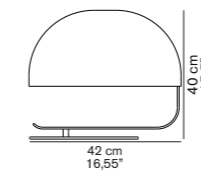

275

pagine/pages



CODICE/CODE	SORGENTI/BULBS	MATERIALI/MATERIALS	COLORE/COLORS	MARCHI/MARKS
275	 1 x max 70 W  E27	metallo/PMMA metal/PMMA	bianco/castano white/nut brown	



SEMPLICE

Sam Hecht
Industrial Facility
2013



226

pagine/ pages

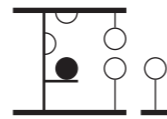
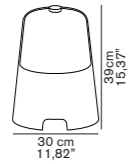

CODICE/CODE	SORGENTI/BULBS	MATERIALI/MATERIALS	COLORE/COLORS	MARCHI/MARKS
226 (dimmer)	 1 x max 75 W E27	metallo/vetro metal/glass	rame satinato/nero opaco – trasparente satin copper/black matt – transparent	











SPIDER
Joe Colombo
1965

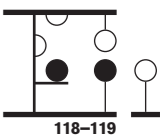
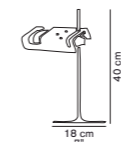

291

pagine/pages



CODICE/CODE	SORGENTI/BULBS	MATERIALI/MATERIALS	COLORE/COLORS	MARCHI/MARKS
291	 1 x max 48 W  G9	metallo/alluminio metal/aluminium	bianco/nero white/black	 

ACRILICA



Gianni e Joe
Colombo
1962

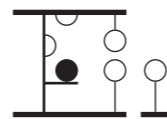
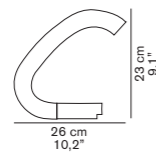

281

pagine/ pages



CODICE/CODE	SORGENTI/BULBS	MATERIALI/MATERIALS	COLORE/COLORS	MARCHI/MARKS
281	 1 x max 6 W  W4,3 x 8,5d	metallo/PMMA metal/PMMA	trasparente transparent	





COUPÉ
Joe Colombo
1967



2202

pagine/pages

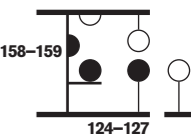
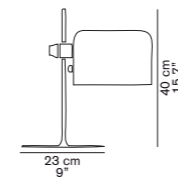

CODICE/CODE	SORGENTI/BULBS	MATERIALI/MATERIALS	COLORE/COLORS	MARCHI/MARKS
2202	1 x max 100 W E27	metallo/alluminio metal/aluminium	bianco/nero white/black	CE UCC



SWITCH

Nendo
2007



206

pagine/pages

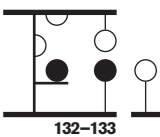
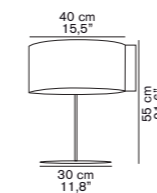

CODICE/CODE	SORGENTI/BULBS	MATERIALI/MATERIALS	COLORE/COLORS	MARCHI/MARKS
206 (dimmer)	2 x max 100 W E27	metallo/metallo metal/metal	nero/oro black/gold	CE



Frank O Gehry
Philip Johnson: The Architect in the New World
Norman Foster Works
EMILIO AMBASZ

HADID
Leonardo da Vinci
Leonardo da Vinci





LUTZ
Lutz Pankow
2009

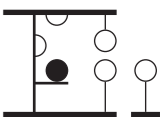
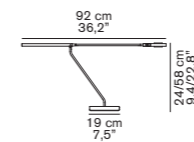

290

pagine/pages



CODICE/CODE	SORGENTI/BULBS	MATERIALI/MATERIALS	COLORE/COLORS	MARCHI/MARKS
290	 1 x max 8 W (LED)	metallo/alluminio metal/aluminium	bianco/nero /cromato white/black/chromium-plated	



LU-LU



Stefano Casciani
1996

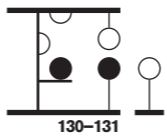
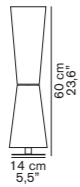

211

pagine/pages



CODICE/CODE	SORGENTI/BULBS	MATERIALI/MATERIALS	COLORE/COLORS	MARCHI/MARKS
211 (dimmer)	 1 x max 100 W – 1 x max 60 W E27	metallo/vetro soffiato metal/blow glass	opale acidato opaline opaque	



DENQToshiyuki Kita
2011

229

pagine/ pages

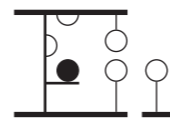
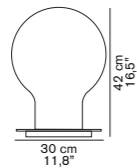

CODICE/CODE	SORGENTI/BULBS	MATERIALI/MATERIALS	COLORE/COLORS	MARCHI/MARKS
229 (dimmer)	1 x max 120 W E27	metallo/vetro soffiato metal/blow glass	opale acidato opaline opaque	CE



STONE OF GLASS

Laudani & Romanelli
2001



202

203

204

pagine/ pages

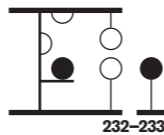
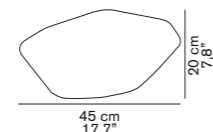
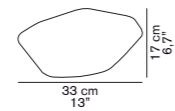
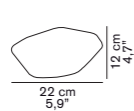

232-233

CODICE/CODE	SORGENTI/BULBS	MATERIALI/MATERIALS	COLORE/COLORS	MARCHI/MARKS
202 (dimmer)	1 x max 60 W E27	PBT/vetro soffiato PBT/blow glass	opale acidato opaline opaque	CE (UL) CCC
203 (dimmer)	1 x max 75 W E27	PBT/vetro soffiato PBT/blow glass	opale acidato opaline opaque	CE (UL) CCC
204 (dimmer)	1 x max 100 W E27	PBT/vetro soffiato PBT/blow glass	opale acidato opaline opaque	CE (UL) CCC



CAND-LED

Laudani & Romanelli
2005



205

pagine/ pages

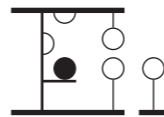
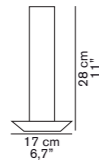

CODICE/CODE	SORGENTI/BULBS	MATERIALI/MATERIALS	COLORE/COLORS	MARCHI/MARKS
205	1 x max 1W (LED)	alluminio/PMMA aluminium/PMMA	trasparente transparent	CE



LAMPADE DA TERRA / FLOOR LAMPS

ACRILICA
 AGNOLI
 ASTRO
 ATOLLO
 CAND-LED
 CANOPY
 CIRCLES
 COLOMBO
 COROA
 COUPÉ
 DENQ
 DIM
 DO WITH
 DUCA
 EMPTY
 FIORE
 FRESNEL
 JK
 KELLY
 KIN
 LANTERNA
 LANTERNINA

LAS
 LENS
 LINE
 LU-LU
 LUTZ
 LYNDON
 LYS
 PASCAL
 PILL-LOW
 PLATEAU
 SEMPLICE
 SIXTY
 SONORA
 SPIDER
 STONE OF GLASS
 STONES
 SUPERLUNA
 SWITCH
 THE GLOBE
 VOILÀ
 YOLK
 ZANUSO

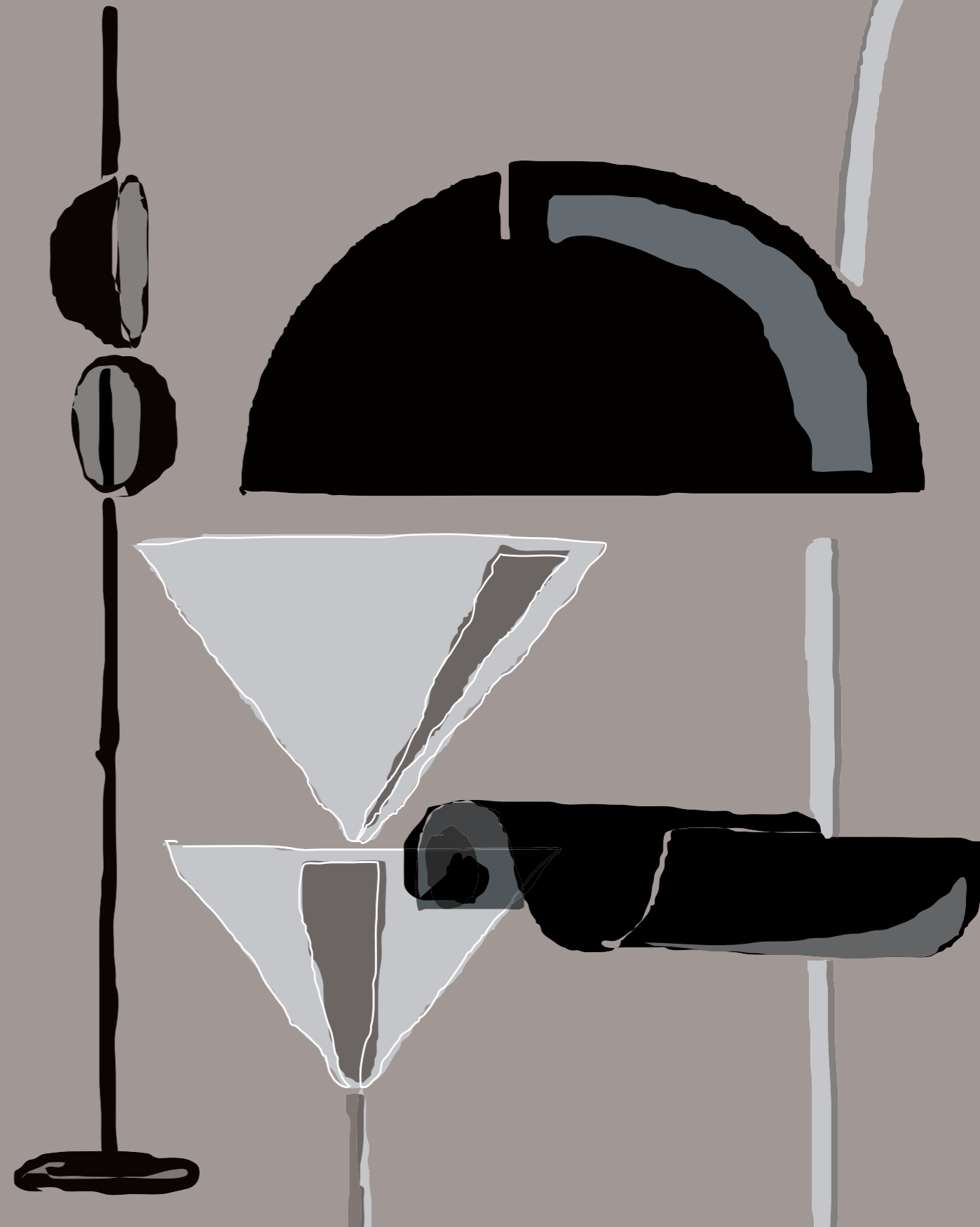



LAS
Mist-o
2015

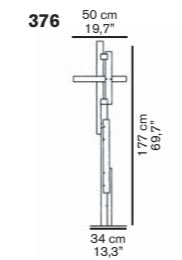

pagine/pages

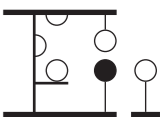

CODICE/CODE	SORGENTI/BULBS	MATERIALI/MATERIALS	COLORE/COLORS	MARCHI/MARKS
376	 3 x max 18 W LED	metallo metal	nero opaco – nero/grigio matt black – black/grey	



SUPERLUNA

Victor Vasilev
2015

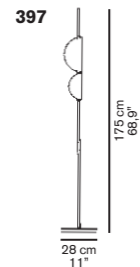

pagine/pages

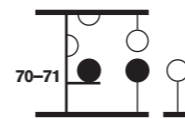

CODICE/CODE	SORGENTI/BULBS	MATERIALI/MATERIALS	COLORE/COLORS	MARCHI/MARKS
397	 2 x max 7,5 W LED 24 V	metallo metal	ottone – asta nera / nero – asta nera brass – black stem / black – black stem	









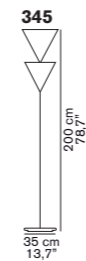

PASCAL
Vico Magistretti
1983

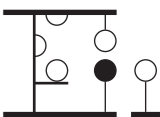

pagine/ pages



CODICE/CODE	SORGENTI/BULBS	MATERIALI/MATERIALS	COLORE/COLORS	MARCHI/MARKS
345	 2 x max 100 W – 1 x max 300 W  R7s.15  E27	metallo/alluminio metal/aluminium	bianco white	







SPIDER

Joe Colombo
1965

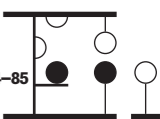

pagine/ pages



CODICE/CODE	SORGENTI/BULBS	MATERIALI/MATERIALS	COLORE/COLORS	MARCHI/MARKS
3319	 1 x max 48 W  G9	metallo/alluminio metal/aluminium	bianco/nero white/black	

COUPÉJoe Colombo
1967

3320/R

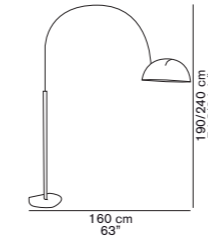

pagine/pages

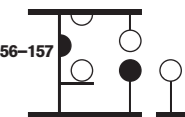
**CODICE/CODE**

3320/R

SORGENTI/BULBS

☀ 1 x max 100 W
💡 E27

MATERIALI/MATERIALS

metallo/alluminio
metal/aluminium

COLORE/COLORS

bianco/nero
white/black

MARCHI/MARKS



**COUPÈ**

Joe Colombo
1967

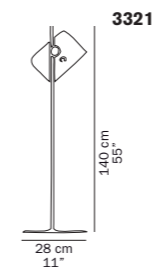

pagine/pages



CODICE/CODE	SORGENTI/BULBS	MATERIALI/MATERIALS	COLORE/COLORS	MARCHI/MARKS
3321	1 x max 100 W E27	metallo/alluminio metal/aluminium	bianco/nero white/black	CE (V) CCC



AGNOLITito Agnoli
1955

pagine/ pages

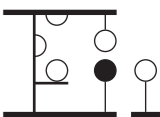

CODICE/CODE	SORGENTI/BULBS	MATERIALI/MATERIALS	COLORE/COLORS	MARCHI/MARKS
387	1 x max 48 W G9	metallo/metallo metal/ metal	nickel satinato satin nickel	CE



LU-LU
Stefano Casciani
1996

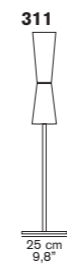

pagine/pages

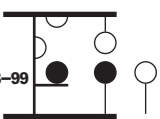

CODICE/CODE	SORGENTI/BULBS	MATERIALI/MATERIALS	COLORE/COLORS	MARCHI/MARKS
311 (dimmer)	1 x max 100 W – 1 x max 60 W E27	metallo/vetro soffiato metal/blow glass	opale acidato opaline opaque	CE

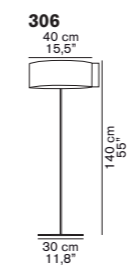
SWITCHNendo
2007

pagine/ pages



CODICE/CODE	SORGENTI/BULBS	MATERIALI/MATERIALS	COLORE/COLORS	MARCHI/MARKS
306 (dimmer)	2 x max 100 W E27	metallo/metallo metal/metal	nero/oro black/gold	CE

DO WITH
Carlo Colombo
2003

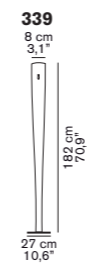

pagine/pages

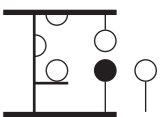

CODICE/CODE	SORGENTI/BULBS	MATERIALI/MATERIALS	COLORE/COLORS	MARCHI/MARKS
339 (dimmer)	1 x max 205 W B15d	alluminio/alluminio aluminium/aluminium	bianco/nero/alluminio white/black/aluminium	CE



Books on a shelf

TV on a cabinet

Pig
aller

Abacus

Book on coffee table

COLOMBOJoe Colombo
1970

626

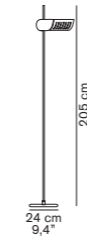

pagine/ pages

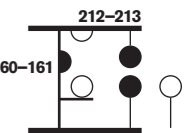
**CODICE/CODE**626
(dimmer)**SORGENTI/BULBS**1 x max 300 W
R7s.15**MATERIALI/MATERIALS**metallo/alluminio
metal/aluminium**COLORE/COLORS**bianco/nero/alluminio
white/black/aluminium**MARCHI/MARKS**

DIM

Vico Magistretti
1975





333

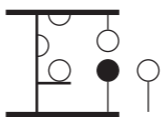

pagine/ pages



CODICE/CODE	SORGENTI/BULBS	MATERIALI/MATERIALS	COLORE/COLORS	MARCHI/MARKS
333 (dimmer)	 1 x max 300 W  R7s.15	metallo/alluminio metal/aluminium	bianco/nero white/black	



**LAMPADE DA PARETE – SOFFITTO /
WALL – CEILING LAMPS**

ACRILICA
AGNOLI
ASTRO
ATOLLO
CAND-LED
CANOPY
CIRCLES
COLOMBO
COROA
COUPÉ
DENO
DIM
DO WITH
DUCA
EMPTY
FIORE
FRESNEL
JK
KELLY
KIN
LANTERNA
LANTERNINA

LAS
LENS
LINE
LU-LU
LUTZ
LYNDON
LYS
PASCAL
PILL-LOW
PLATEAU
SEMPLICE
SIXTY
SONORA
SPIDER
STONE OF GLASS
STONES
SUPERLUNA
SWITCH
THE GLOBE
VOILÀ
YOLK
ZANUSO

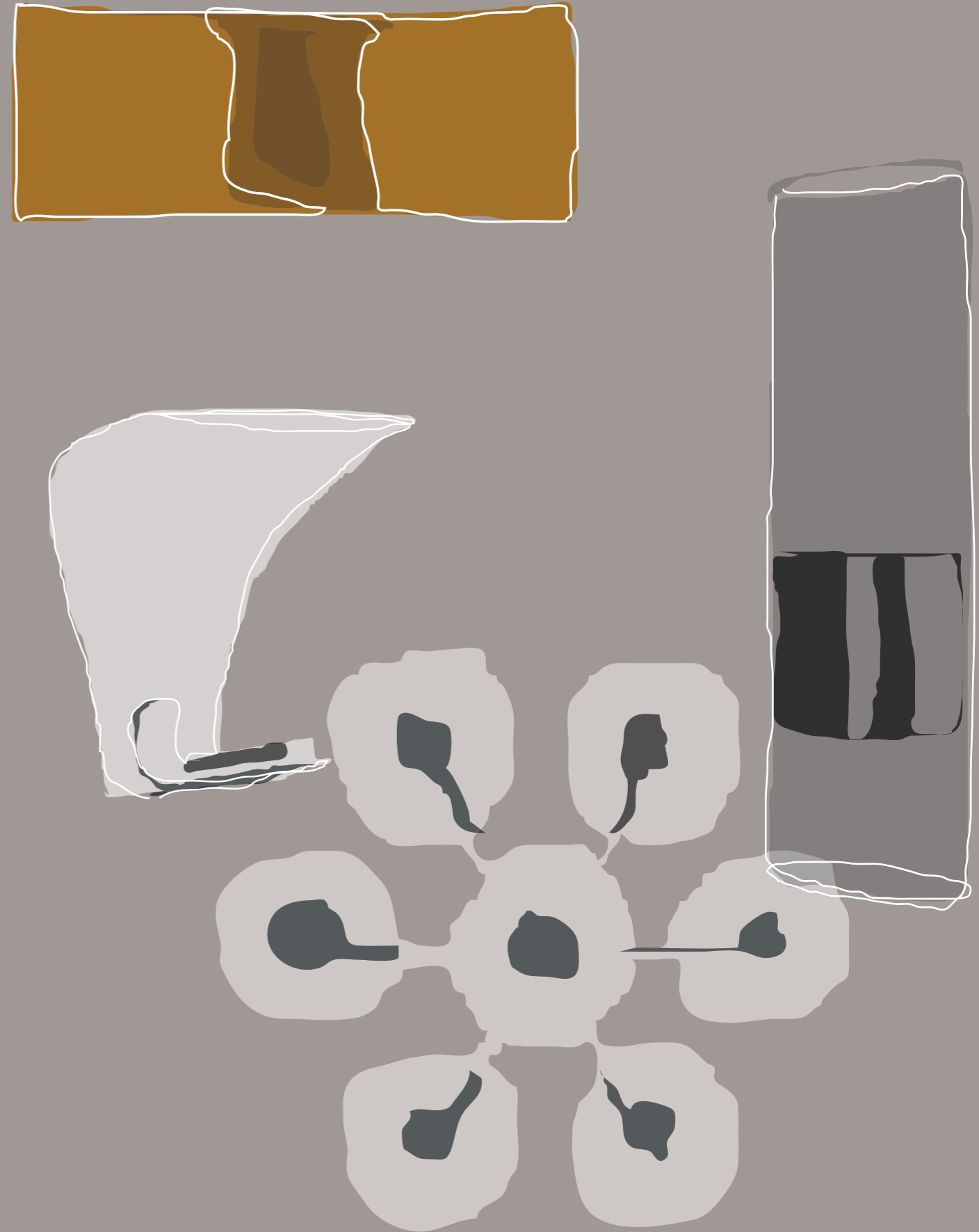

THE GLOBEJoe Colombo
1964

727

pagine/pages

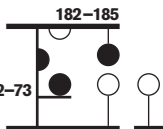
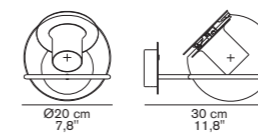
**CODICE/CODE****SORGENTI/BULBS****MATERIALI/MATERIALS****COLORE/COLORS****MARCHI/MARKS**

727

1 x max 40 W
E14metallo/vetro soffiato
metal/blow glassnickel satinato - oro satinato/anodic bronzo
satin nickel - satin gold/anodic bronze

DUCA
Nicola Gallizia
2015



1950

pagine/pages

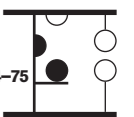
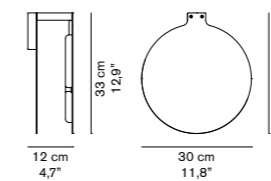

CODICE/CODE	SORGENTI/BULBS	MATERIALI/MATERIALS	COLORE/COLORS	MARCHI/MARKS
1950	1 x max 14 W LED 220V	metallo metal	grigio caldo warm grey	CE



ASTRO
Giopato&Coombes
2015



1188

pagine/pages

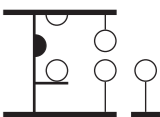
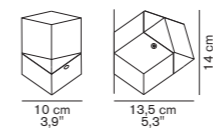

CODICE/CODE	SORGENTI/BULBS	MATERIALI/MATERIALS	COLORE/COLORS	MARCHI/MARKS
1188	 1 x max 33 W  G9	metallo/vetro stampato metal/moulded glass	bianco/nero/trasparente white/black/transparent	



LENS
 Francesco Rota
 2013

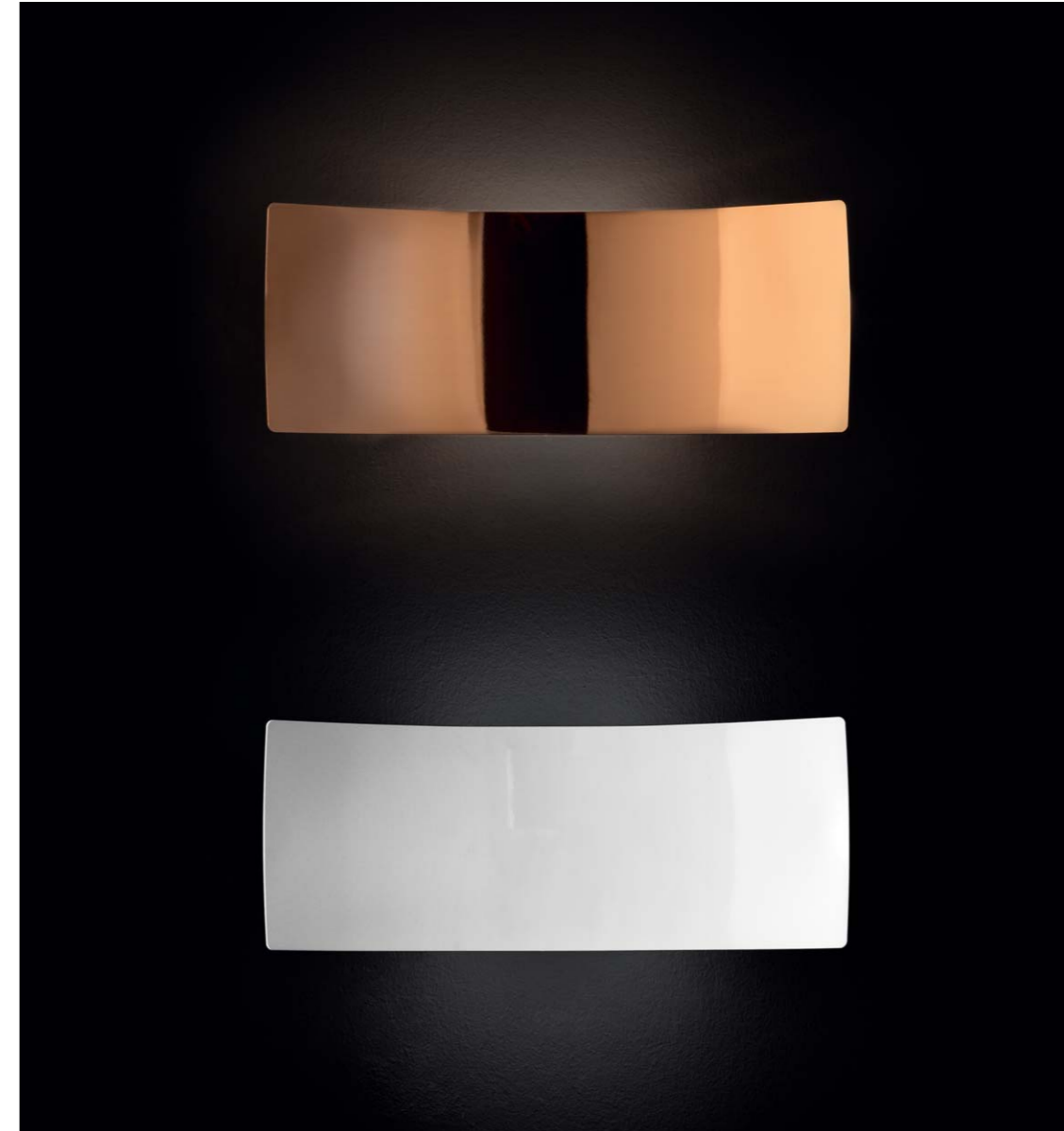

151

pagine/pages

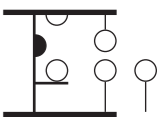
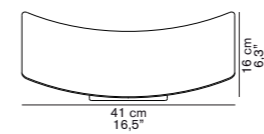

CODICE/CODE	SORGENTI/BULBS	MATERIALI/MATERIALS	COLORE/COLORS	MARCHI/MARKS
151	 1 x max 120 W R7s.15	metallo metal	bianco/rame lucido white/glossy copper	



COUPÈJoe Colombo
1967

1159/R

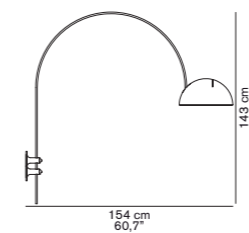

pagine/pages

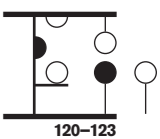
**CODICE/CODE**

1159/R

SORGENTI/BULBS

☀️ 1 x max 100 W
💡 E27

MATERIALI/MATERIALS

metallo/alluminio
metal/aluminium

COLORE/COLORS

bianco/nero
white/black

MARCHI/MARKS

COUPÉ

Joe Colombo
1967



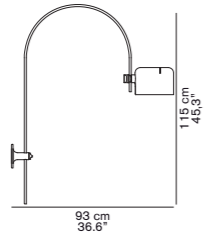

1158

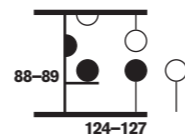

pagine/pages



CODICE/CODE	SORGENTI/BULBS	MATERIALI/MATERIALS	COLORE/COLORS	MARCHI/MARKS
1158	 1 x max 100 W  E27	metallo/alluminio metal/aluminium	bianco/nero white/black	



COLOMBO



Joe Colombo
1970

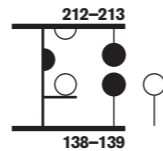
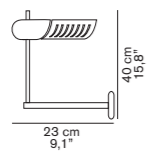

761

pagine/ pages



CODICE/CODE	SORGENTI/BULBS	MATERIALI/MATERIALS	COLORE/COLORS	MARCHI/MARKS
761	 1 x max 300 W  R7s.15	metallo/alluminio metal/aluminium	bianco/nero white/black	







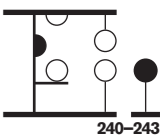
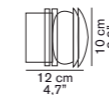

FRESNELJoe Colombo
1966

1148 - 1148/L

pagine/pages



CODICE/CODE	SORGENTI/BULBS	MATERIALI/MATERIALS	COLORE/COLORS	MARCHI/MARKS
1148	 1 x max 40 W E14	metallo / vetro trasparente sabbiato metal / glass sand blasted transparent	bianco/nero/grigio/cromato white/black/grey/ chromium plated	  
1148/L	 1 x max 4,5 W (LED) 220 V	metallo / vetro trasparente sabbiato metal / glass sand blasted transparent	bianco/nero/grigio/cromato white/black/grey/ chromium plated	 IP44

VOILÀFerdì Giardini
2014

103

pagine/pages

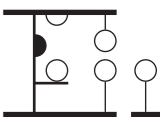
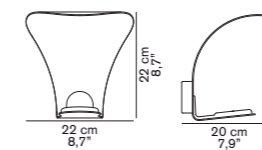

CODICE/CODE	SORGENTI/BULBS	MATERIALI/MATERIALS	COLORE/COLORS	MARCHI/MARKS
199	 1 x max 13 W (LED) 220 V	metallo metal	bianco opaco matt white	

YOLKAngeletti & Ruzza
2014

103

pagine/pages

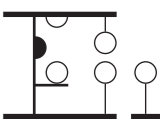
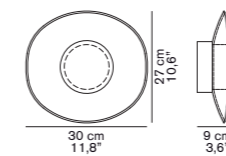
**CODICE/CODE****SORGENTI/BULBS****MATERIALI/MATERIALS****COLORE/COLORS****MARCHI/MARKS**

169

1 x max 60 W
G9metallo/vetro soffiato
metal/blow glasstrasparente/opale
transparent/opaline



KELLY
Studio 63
2011

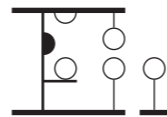
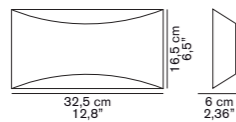

790 – 791

pagine/ pages



CODICE/CODE	SORGENTI/BULBS	MATERIALI/MATERIALS	COLORE/COLORS	MARCHI/MARKS
790	 1 x max 120 W R7s.15	metallo/metallo metal/metal	bianco/cromato white/chromium plated	CE
791	 2 x max 6 W (LED)	metallo/metallo metal/metal	bianco/cromato white/chromium plated	CE 





FIORE
Laudani & Romanelli
2007

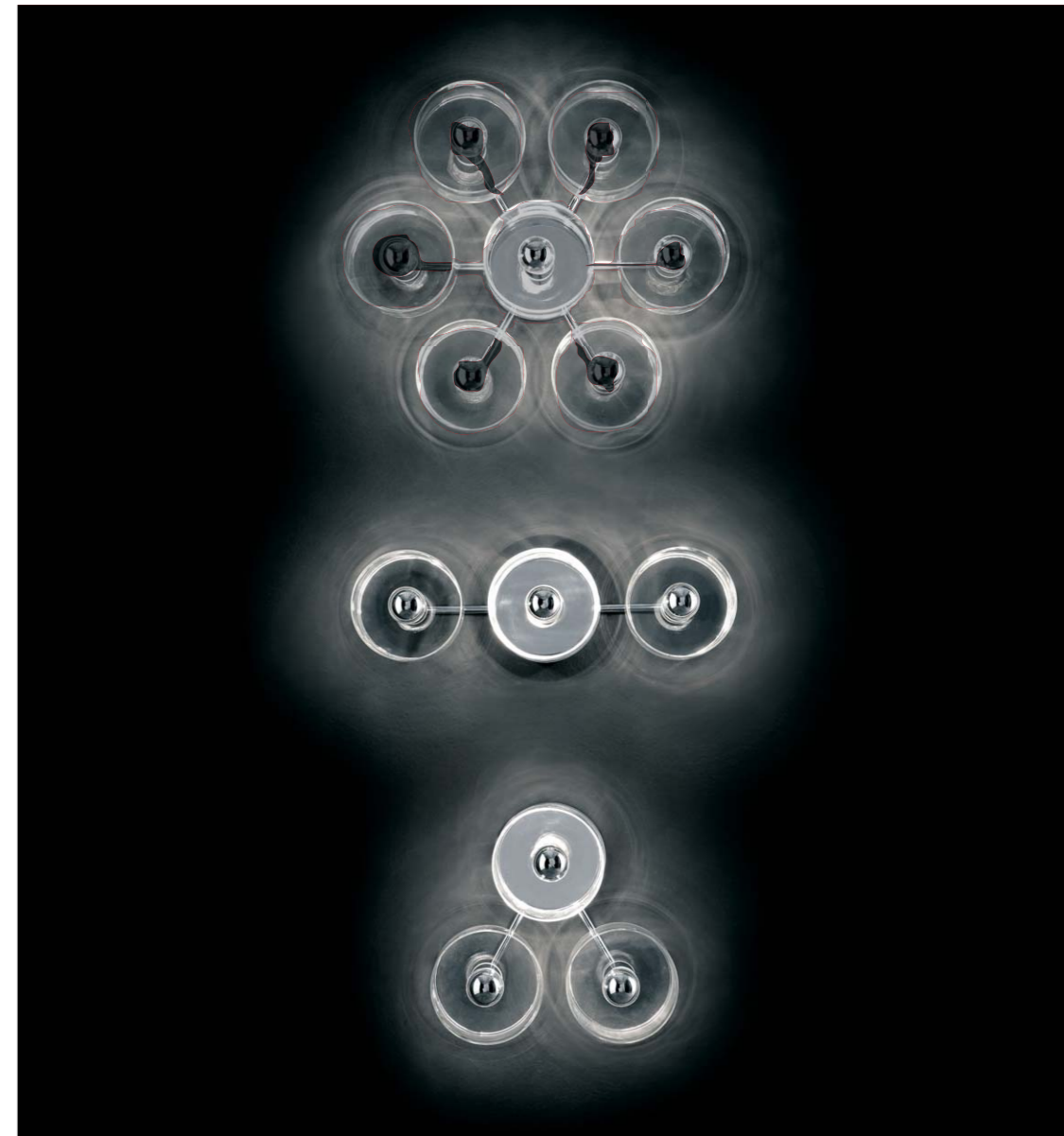

103

123

173

139

pagine/pages

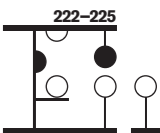
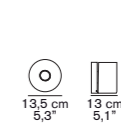
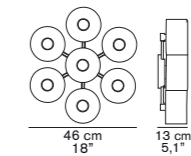
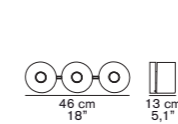
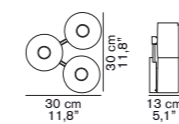

CODICE/CODE	SORGENTI/BULBS	MATERIALI/MATERIALS	COLORE/COLORS	MARCHI/MARKS
103	3 x max 40 W E14	metallo/vetro soffiato metal/blow glass	trasparente transparent	CE (V)
123	3 x max 40 W E14	metallo/vetro soffiato metal/blow glass	trasparente transparent	CE (V)
173	7 x max 40 W E14	metallo/vetro soffiato metal/blow glass	trasparente transparent	CE (V)
139	1 x max 40 W E14	metallo/vetro soffiato metal/blow glass	trasparente transparent	CE (V)

LINE

Francesco Rota
2009



147

149

pagine/pages



CODICE/CODE	SORGENTI/BULBS	MATERIALI/MATERIALS	COLORE/COLORS	MARCHI/MARKS
147	2 x max 40 W G9	alluminio/vetro pyrex aluminium/pyrex glass	trasparente transparent	CE UK
149	2 x max 40 W G9	alluminio/vetro pyrex aluminium/pyrex glass	trasparente transparent	CE UK



JK



Francesco Rota
2011

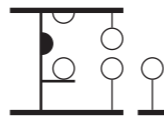
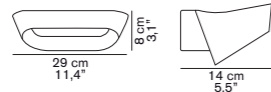

780

pagine/ pages



CODICE/CODE	SORGENTI/BULBS	MATERIALI/MATERIALS	COLORE/COLORS	MARCHI/MARKS
780	 1 x max 160 W R7s.15	metallo/alluminio metal/aluminium	bianco/nero opaco white/black matt	







**LYNDON**Vico Magistretti
1977

160

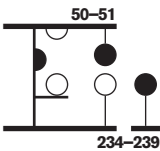
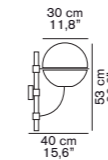
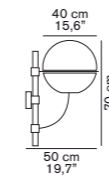
160/M

pagine/ pages



CODICE/CODE	SORGENTI/BULBS	MATERIALI/MATERIALS	COLORE/COLORS	MARCHI/MARKS
160	 1 x max 100 W E27	metallo / policarbonato metal / polycarbonate	nero / trasparente black / transparent	
160/M	 1 x max 100 W E27	metallo / policarbonato metal / polycarbonate	nero / trasparente black / transparent	

SIXTY

O luce
2006







107

127

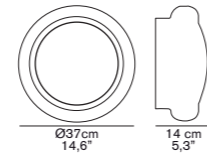
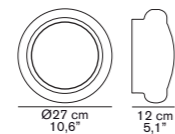
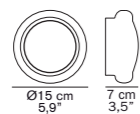
137

pagine/ pages



CODICE/CODE	SORGENTI/BULBS	MATERIALI/MATERIALS	COLORE/COLORS	MARCHI/MARKS
107	 1 x max 40 W G9	metallo/vetro soffiato metal/blow glass	opale acidato opaline opaque	CE
127	 2 x max 60 W E27	metallo/vetro soffiato metal/blow glass	opale acidato opaline opaque	CE (L)
137	 2 x max 75 W E27	metallo/vetro soffiato metal/blow glass	opale acidato opaline opaque	CE (L)



**LAMPADE A SOSPENSIONE /
SUSPENSION LAMPS**

ACRILICA
AGNOLI
ASTRO
ATOLLO
CAND-LED
CANOPY
CIRCLES
COLOMBO
COROA
COUPÉ
DENO
DIM
DO WITH
DUCA
EMPTY
FIORE
FRESNEL
JK
KELLY
KIN
LANTERNA
LANTERNINA

LAS
LENS
LINE
LU-LU
LUTZ
LYNDON
LYS
PASCAL
PILL-LOW
PLATEAU
SEMPLICE
SIXTY
SONORA
SPIDER
STONE OF GLASS
STONES
SUPERLUNA
SWITCH
THE GLOBE
VOILÀ
YOLK
ZANUSO



THE GLOBEJoe Colombo
1964

827

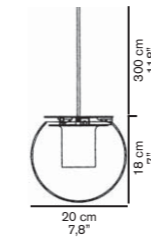

828

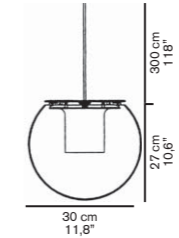

pagine/pages

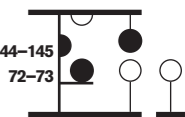
**CODICE/CODE****SORGENTI/BULBS****MATERIALI/MATERIALS****COLORE/COLORS****MARCHI/MARKS**

827

☼ 1 x max 40 W
E14

metallo/vetro soffiato
metal/blow glass

nickel satinato - oro satinato/anodico bronzo
satin nickel - satin gold/anodic bronze



828

☼ 1 x max 60 W
E27

metallo/vetro soffiato
metal/blow glass

nickel satinato - oro satinato/anodico bronzo
satin nickel - satin gold/anodic bronze







KIN
 Francesco Rota
 2012



478

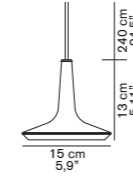

479

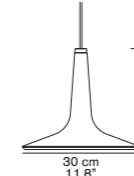

pagine/ pages

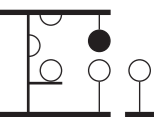

CODICE/CODE	SORGENTI/BULBS	MATERIALI/MATERIALS	COLORE/COLORS	MARCHI/MARKS
478	1 x max 4,5 W (LED) 220 V	metallo/PMMA metal/PMMA	bianco/nero/rame lucido white/black/glossy copper	CE
479	1 x max 13,5 W (LED) 220 V	metallo/PMMA metal/PMMA	bianco/nero/rame lucido white/black/glossy copper	CE





LYS
Angeletti & Ruzza
2013

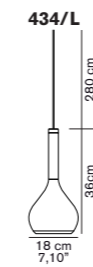

pagine/pages

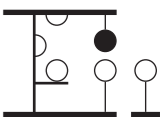

CODICE/CODE	SORGENTI/BULBS	MATERIALI/MATERIALS	COLORE/COLORS	MARCHI/MARKS
434/L	1 x max 13 W (LED) 220 V	metallo/PMMA metal/PMMA	bianco/rame lucido white/glossy copper	CE



EMPTY

Jörg Boner
2013



439/L

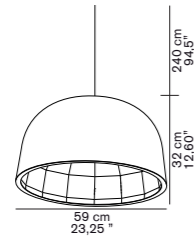

pagine/pages

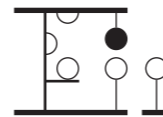

CODICE/CODE	SORGENTI/BULBS	MATERIALI/MATERIALS	COLORE/COLORS	MARCHI/MARKS
439/L	1 x max 17,5 W (LED) 220 V	alluminio aluminium	bianco/rame satinato – bronzo/rame satinato white/satin copper – bronze/satin copper	CE





SONORA
Vico Magistretti
1976



408

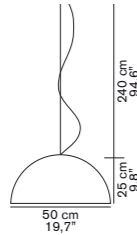

437

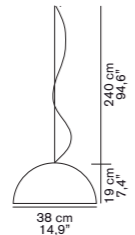

pagine/pages

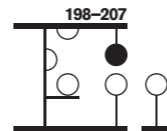

CODICE/CODE	SORGENTI/BULBS	MATERIALI/MATERIALS	COLORE/COLORS	MARCHI/MARKS
408	1 x max 60 W E27	metallo metal	nero – oro black – gold	CE (UL)
437	1 x max 60 W E27	metallo metal	nero – oro black – gold	CE (UL)



SONORA

Vico Magistretti
1976



490 - 490/OR

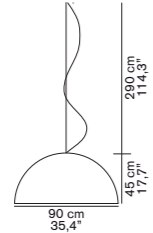

493

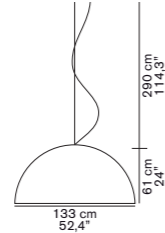

pagine/ pages

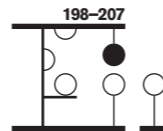

CODICE/CODE	SORGENTI/BULBS	MATERIALI/MATERIALS	COLORE/COLORS	MARCHI/MARKS
490	1 x max 150 W E27	metallo/PMMA metal/PMMA	opale/bianco coprente/nero opaline/painted white/black	CE (UL) CCC
490/OR	1 x max 150 W E27	metallo/PMMA metal/PMMA	esterno bianco/nero - interno oro white outside/black - gold inside	CE (UL) CCC
493	2 x max 150 W E27	metallo/PMMA metal/PMMA	opale/bianco coprente opaline/painted white	CE (UL) CCC





SONORA
Vico Magistretti
1976



411

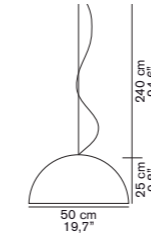

438

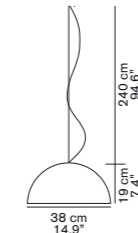

pagine/pages

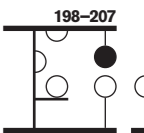

CODICE/CODE	SORGENTI/BULBS	MATERIALI/MATERIALS	COLORE/COLORS	MARCHI/MARKS
411	2 x max 100 W E27	metallo/vetro soffiato metal/blow glass	opale acidato opaline opaque	CE (V) CCC
438	1 x max 100 W E27	metallo/vetro soffiato metal/blow glass	opale acidato opaline opaque	CE (V) CCC



CANOPY

Francesco Rota
2009



421

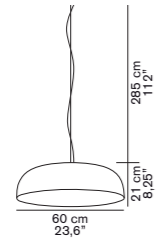

422

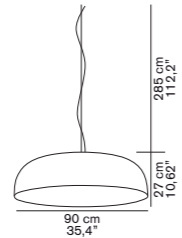

pagine/ pages

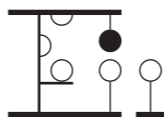

CODICE/CODE	SORGENTI/BULBS	MATERIALI/MATERIALS	COLORE/COLORS	MARCHI/MARKS
421	1 x max 55 W 2GX13	alluminio aluminium	bianco – bianco/melone – bronzo/bianco white – white/melon – bronze/white	CE (UL) ENEC
422	1 x max 55 W 2GX13	alluminio aluminium	bianco – bianco/melone – bronzo/bianco white – white/melon – bronze/white	CE (UL) ENEC







COLOMBO
Joe Colombo
1970

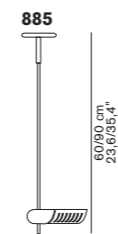

pagine/pages

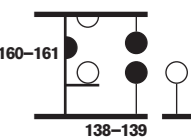

CODICE/CODE	SORGENTI/BULBS	MATERIALI/MATERIALS	COLORE/COLORS	MARCHI/MARKS
885	1 x max 300 W R7s.15	metallo/alluminio metal/aluminium	bianco/nero white/black	CE

PLATEAU

Antonia Astori
e Nicola De Ponti
2009

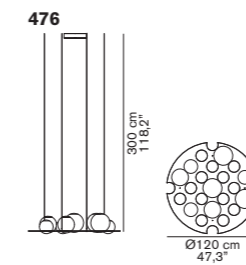

pagine/pages

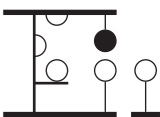

CODICE/CODE	SORGENTI/BULBS	MATERIALI/MATERIALS	COLORE/COLORS	MARCHI/MARKS
476	8 x max 40 W E14	PMMA trasparente/vetro soffiato PMMA transparent/blow glass	opale acidato opaline opaque	CE

COROA
Emmanuel Babled
2009



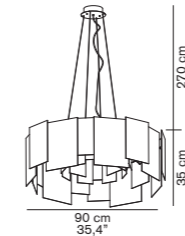

480

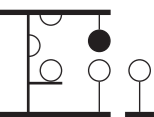

pagine/ pages



CODICE/CODE	SORGENTI/BULBS	MATERIALI/MATERIALS	COLORE/COLORS	MARCHI/MARKS
480	 16 x max 25 W E27	metallo/PMMA metal/PMMA	bispecchio double-face mirror	

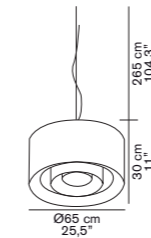

**CIRCLES**Laudani & Romanelli
2011

429

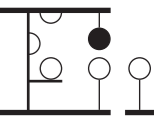

pagine/pages



CODICE/CODE	SORGENTI/BULBS	MATERIALI/MATERIALS	COLORE/COLORS	MARCHI/MARKS
429	 4 x max 20 W  E27 (fluo)	metallo/tessuto metal/fabric	esterno bianco – interno argento/esterno marrone – interno oro white outside – silver inside/ brown outside – gold inside	



FIORE

Laudani & Romanelli
2007



423

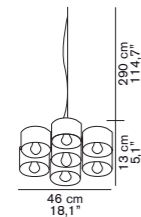



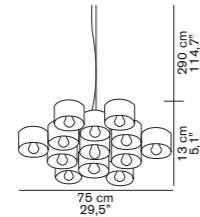



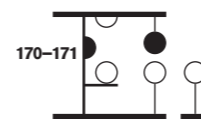

433



pagine/ pages



CODICE/CODE	SORGENTI/BULBS	MATERIALI/MATERIALS	COLORE/COLORS	MARCHI/MARKS
423	 7 x max 40 W  E14	metallo/vetro soffiato metal/blow glass	trasparente transparent	 
433	 13 x max 25 W  E14	metallo/vetro soffiato metal/blow glass	trasparente transparent	 







**LANTERNA
LANTERNINA**

Laudani & Romanelli
1998



471

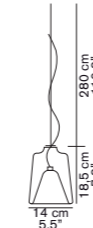

477

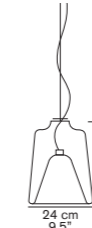

pagine/pages

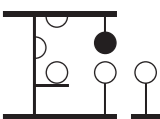

CODICE/CODE	SORGENTI/BULBS	MATERIALI/MATERIALS	COLORE/COLORS	MARCHI/MARKS
471	1 x max 40 W E14	alluminio/vetro soffiato aluminium/blown glass	trasparente sabbiato transparent sand blasted	CE
477	1 x max 100 W E27	alluminio/vetro soffiato aluminium/blown glass	trasparente sabbiato transparent sand blasted	CE



LAMPADE DA ESTERNO / OUTSIDE LAMPS

ACRILICA
 AGNOLI
 ASTRO
 ATOLLO
 CAND-LED
 CANOPY
 CIRCLES
 COLOMBO
 COROA
 COUPÉ
 DENQ
 DIM
 DO WITH
 DUCA
 EMPTY
 FIORE
FRESNEL
 JK
 KELLY
 KIN
 LANTERNA
 LANTERNINA

LAS
 LENS
 LINE
 LU-LU
 LUTZ
LYNDON
 LYS
 PASCAL
PILL-LOW
 PLATEAU
 SEMPLICE
 SIXTY
 SONORA
 SPIDER
 STONE OF GLASS
STONES
 SUPERLUNA
 SWITCH
 THE GLOBE
 VOILÀ
 YOLK
 ZANUSO

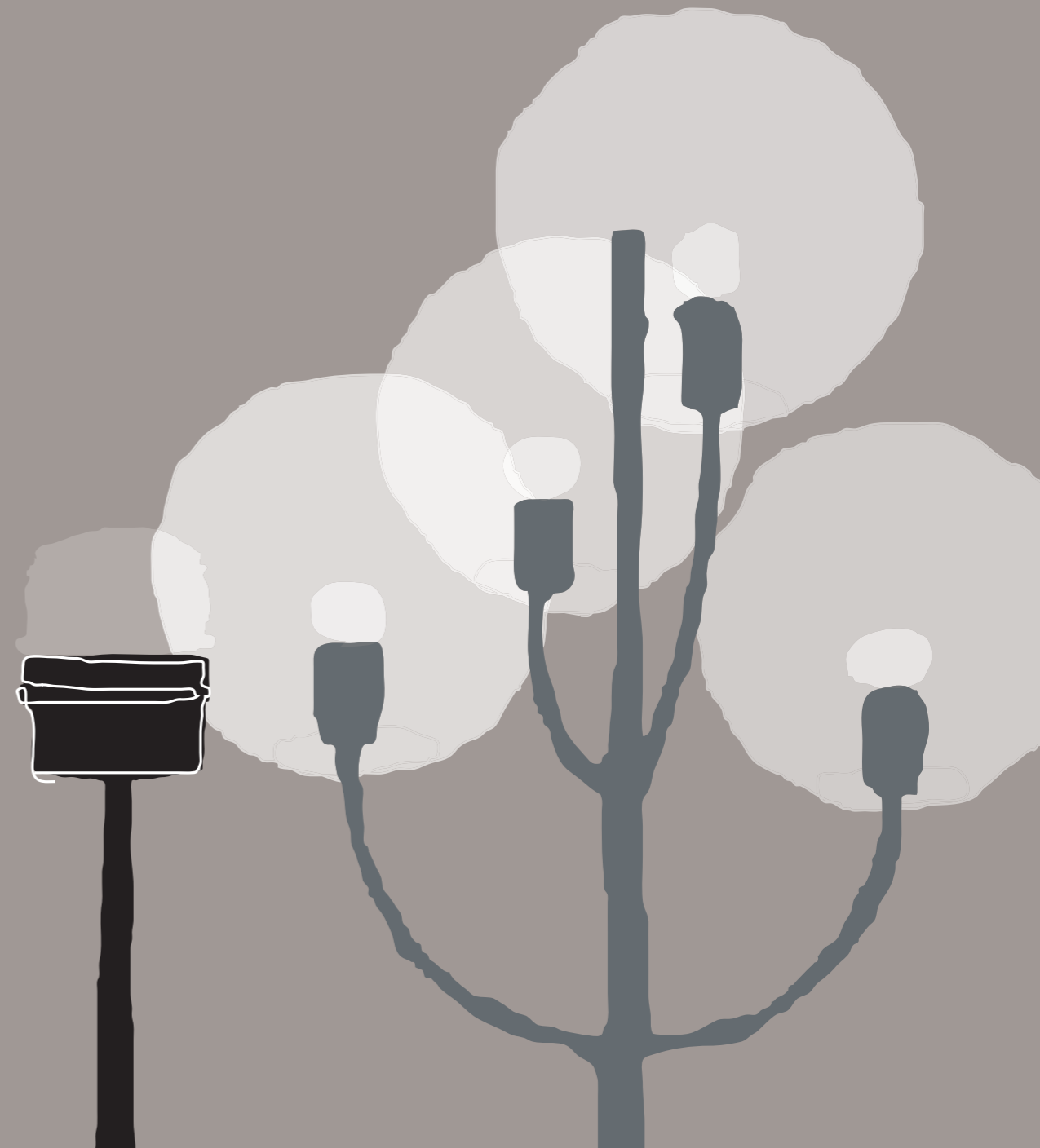

STONESLaudani & Romanelli
2002

207

208

215

pagine/pages

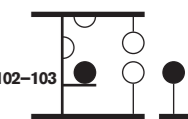
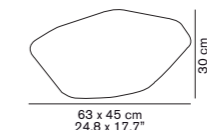
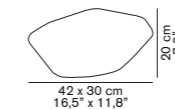
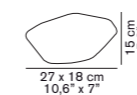

CODICE/CODE	SORGENTI/BULBS	MATERIALI/MATERIALS	COLORE/COLORS	MARCHI/MARKS
207	1 x max 12 W E27 (fluo)	nylon/polietilene nylon/polyethylene	bianco white	CE IP65
208	1 x max 25 W E27 (fluo)	nylon/polietilene nylon/polyethylene	bianco white	CE IP65
215	1 x max 25 W E27 (fluo)	nylon/polietilene nylon/polyethylene	bianco white	CE IP65

LYNDON

Vico Magistretti
1977

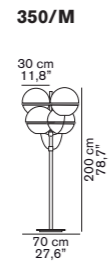
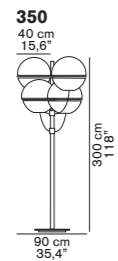

pagine/ pages

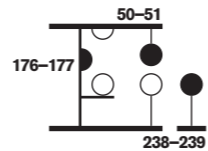

CODICE/CODE	SORGENTI/BULBS	MATERIALI/MATERIALS	COLORE/COLORS	MARCHI/MARKS
350	4 x max 100 W E27	metallo nero/polycarbonato black metal/polycarbonate	trasparente transparent	IP23
350/M	4 x max 100 W E27	metallo nero/polycarbonato black metal/polycarbonate	trasparente transparent	IP23







LYNDON
Vico Magistretti
1977



160

160/M

pagine/ pages

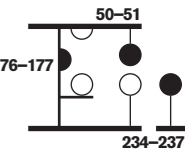
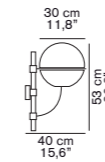
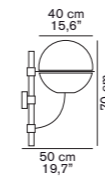

CODICE/CODE	SORGENTI/BULBS	MATERIALI/MATERIALS	COLORE/COLORS	MARCHI/MARKS
160	1 x max 100 W E27	metallo nero/polycarbonato black metal/polycarbonate	trasparente transparent	CEIP23
160/M	1 x max 100 W E27	metallo nero/polycarbonato black metal/polycarbonate	trasparente transparent	CEIP23

FRESNELJoe Colombo
1966

1148/EC

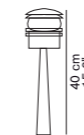





1148/EL

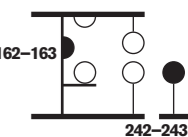

pagine/pages



CODICE/CODE	SORGENTI/BULBS	MATERIALI/MATERIALS	COLORE/COLORS	MARCHI/MARKS
1148/EC	 1 x max 40 W  E14	metallo nero/vetro stampato black metal/moulded glass	trasparente sabbiato sand blasted transparent	CEIP45
1148/EL	 1 x max 40 W  E14	metallo nero/vetro stampato black metal/moulded glass	trasparente sabbiato sand blasted transparent	CEIP45

FRESNEL







Joe Colombo
1966

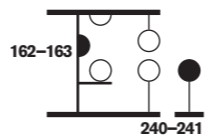
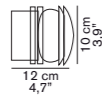

1148 - 1148/L

pagine/ pages



CODICE/CODE	SORGENTI/BULBS	MATERIALI/MATERIALS	COLORE/COLORS	MARCHI/MARKS
1148	 1 x max 40 W  E14	metallo / vetro trasparente sabbiato metal / glass sand blasted transparent	bianco/nero/grigio/cromato white/black/grey/ chromium plated	  
1148/L	 1 x max 4,5 W (LED) 220 V	metallo / vetro trasparente sabbiato metal / glass sand blasted transparent	bianco/nero/grigio/cromato white/black/grey/ chromium plated	 IP44

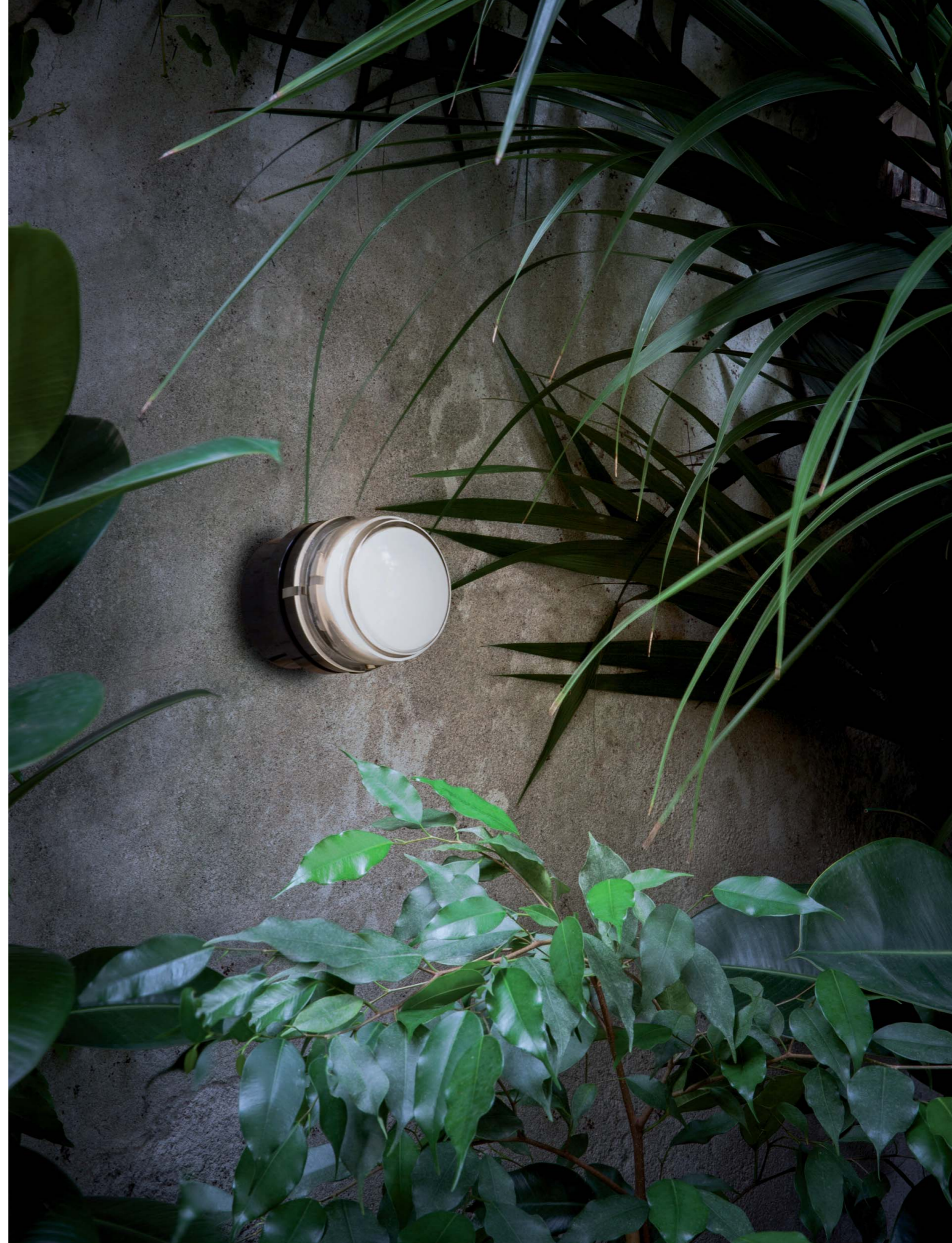





PILL-LOW
 Francesco Rota
 2011



219

pagine/pages

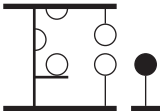

CODICE/CODE	SORGENTI/BULBS	MATERIALI/MATERIALS	COLORE/COLORS	MARCHI/MARKS
219	 1 x max 25 W  E27	polietilene/tessuto polyethylene/fabric	bianco/bianco azzurro – verde – rosso white/white light blue – green – red	 CE IP65



ROSONE SOFFITTO / CEILING ROSE



ALBA 468



FIORE 423,433



SONORA 408-437 (nero/black)
LANTERNA/INA 477, 471
SONORA 438,411
CANOPY 421, 422
CIRCLES 429
EMPTY 439
RECUERDO 484
ALBA 465



LYNDON 450



COLOMBO 885



SONORA 490 NE/ORNE
NIWA 1180



SONORA 490 BI/BC/ORBC
493 BI/BC



KIN 478/479

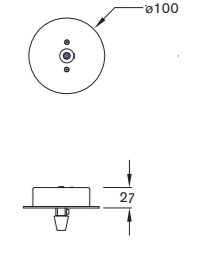
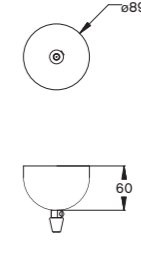
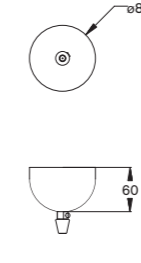
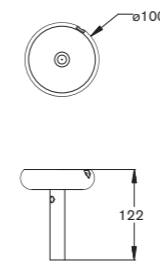
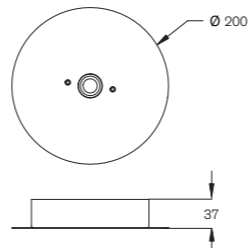
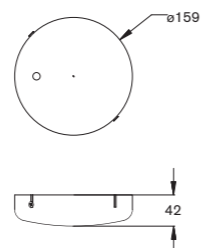
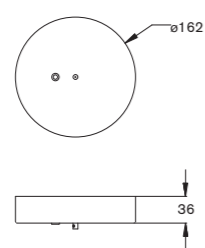
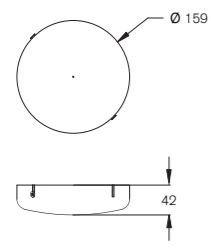

THE GLOBE 827, 828



LYS 434/L



PLATEAU 476



COROA 480

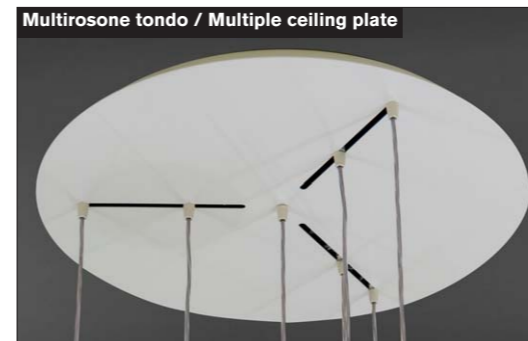

Multirosone tondo / Multiple ceiling plate

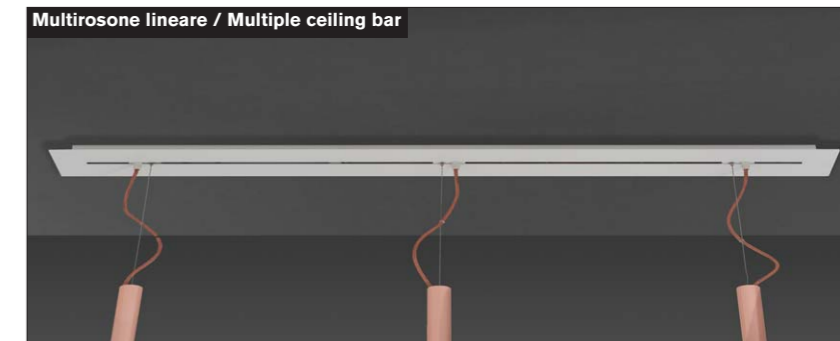

Multirosone lineare / Multiple ceiling bar

KIN 478/479 SR - LANTERNA/INA 477, 471 SR - LYS 434/L SR - ALBA 465 - RECUERDO 484 - NIWA 1180

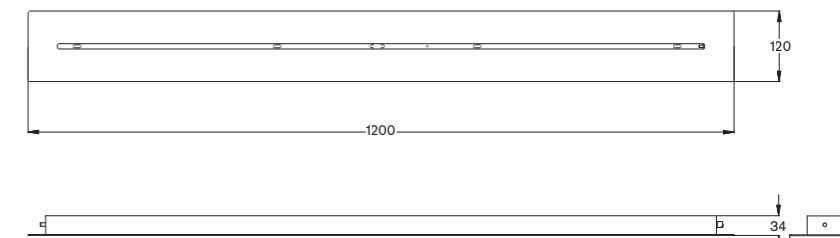
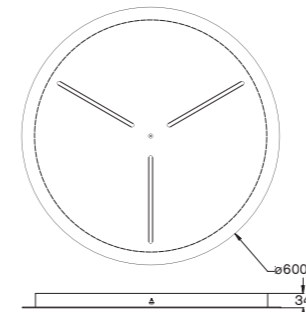
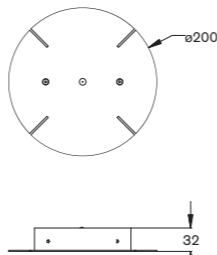
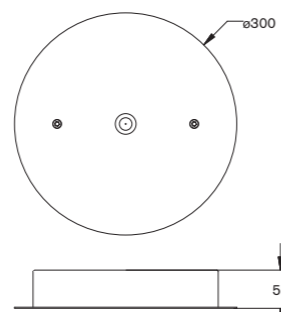
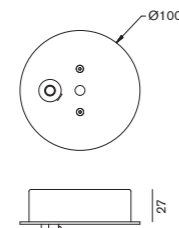
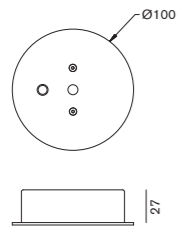

**PREMI E
RICONOSCIMENTI /
AWARDS AND
HONORS**

LANTERNA

	<p>"The state of things" (curated by J. Morrison) Berlin, Brunswick 1999, Köln 2000</p>
	<p>Selezione Compasso d'Oro ADI Milano 2001</p>

PERSONAL 230

	<p>Selezione Compasso d'Oro ADI Milano 1989</p>
--	--

NARA 420

	<p>Selezione Compasso d'Oro ADI Milano 1981</p>
---	--

NUVOLA 195

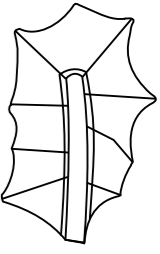
	<p>Selezione Compasso d'Oro ADI Milano 2001</p>
---	--

NUVOLA 196

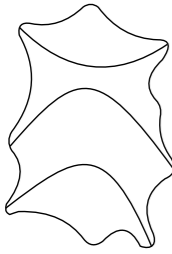
	<p>Selezione Compasso d'Oro ADI Milano 2001</p>
	<p>Compasso d'Oro ADI Milano 1979</p>
	<p>"Kunstgewerbe Museum" Zürich 1983</p>
	<p>"Museum of Modern Art" New York 1979</p>
	<p>Collezione Permanente del Design Italiano, Triennale di Milano</p>

ATOLLO 233

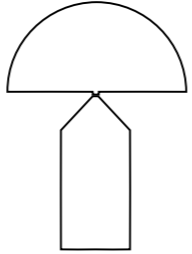
	<p>Museum "Die Neue Sammlung" München 1983</p>
	<p>"Musuem Für Kunst und Gewerbe" Hamburg 1986</p>
	<p>"Philadelphia Museum of Art" Philadelphia 1983</p>
	<p>"Kunstmuseum" Düsseldorf 1989</p>

SPIDER 3319

	<p>"Italy: the New Domestic Landscape" MoMA, New York 1972</p>
	<p>"Kunstmuseum" Düsseldorf 1989</p>
	<p>Collezione Permanente del Design Italiano Triennale di Milano</p>
	<p>"Philadelphia Museum of Art" Philadelphia 1983</p>

SLALOM 299

	<p>Museum "Die Neue Sammlung" München 1983</p>
	<p>Selezione Compasso d'Oro ADI Milano 1984</p>
	<p>"Museum Fuer Angewandte Kunst" Köln 1990</p>

363

	<p>Segnalazione Compasso d'Oro, Milano 1955</p>
---	--

KUTA 250

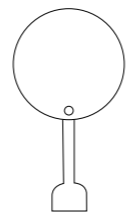
	<p>"Museum Für Kunst und Gewerbe" Hamburg 1986</p>
---	---

DOGALE 512

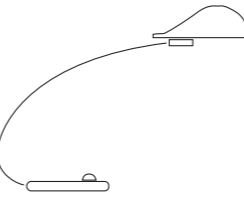
	<p>Museum "Die Neue Sammlung" München 1983</p>
	<p>"Museum Fuer Angewandte Kunst" Köln 1990</p>

POLIVINILE

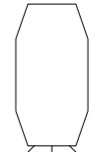
	<p>Segnalazione Compasso d'Oro, Milano 1956</p>
---	--

SPRING

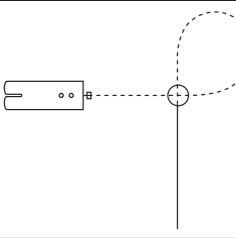
	<p>Segnalazione XIV Triennale Milano 1968</p>
	<p>International Design Award American Institute of Interior Designers Chicago 1970</p>
	<p>Museum of Modern Art New York 1970</p>

SUPERLUNA

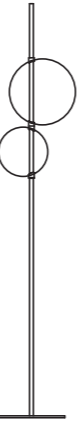
	<p>German Design Award 2018</p>
---	--

BERLIN 720-721

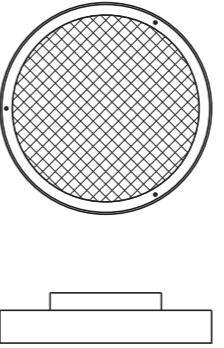
	<p>Archiproducts Design Awards 2017</p>
---	--

COLOMBO 626

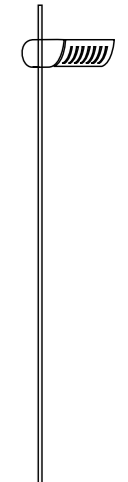
	<p>Museum "Die Neue Sammlung" München 1983</p>
	<p>"Museum Für Angewandte Kunst" Köln 1990</p>
	<p>"Kunstmuseum" Düsseldorf 1989</p>

SNOW 401

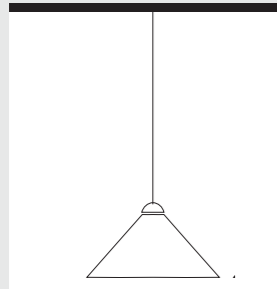

Museum "Die Neue Sammlung"
München 1983

Medaglia d'Oro XIII
Triennale, Milano 1964

ACRILICA 281

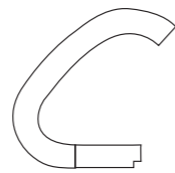

"Kunstgewerbe Museum",
Zürich 1983

Museum of Modern Art,
New York 1999

LID

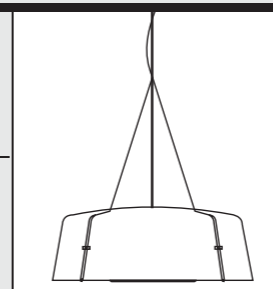

Prix d'excellence
Marie Claire Maison
Paris 1999

"The state of things"
(curated by J. Morrison)
Berlin, Brunswick 1999,
Köln 2000

PERLA 241

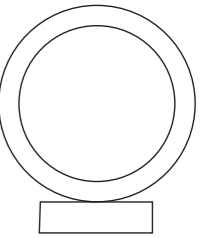

Museum "Die Neue Sammlung"
München 1987

OTELLO 640

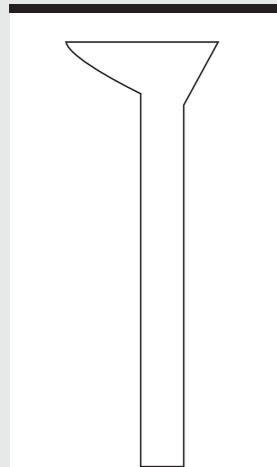

"Museum Für Kunst
und Gewerbe"
Hamburg 1986

Museum "Die Neue
Sammlung",
München 1983

Collezione Permanente
del Design Italiano,
Triennale di Milano

"Philadelphia Museum of
Art", Philadelphia 1983

TEDA 302

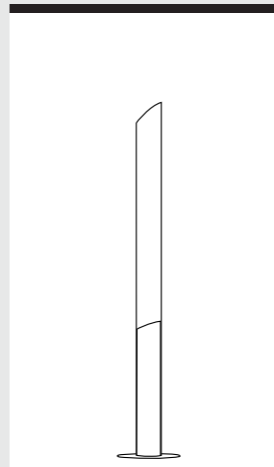

"Light of the future"
Frankfurt 2002

Compasso d'Oro ADI
Milano 1967,

"Italy: the New Domestic
Landscape", MoMA,
New York 1972

SPIDER 291

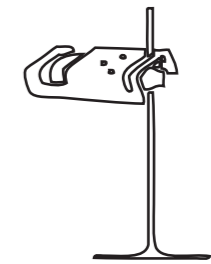

"Philadelphia Museum of
Art", Philadelphia 1983

Museum "Die Neue
Sammlung"
München 1983

IDOMENEO 121

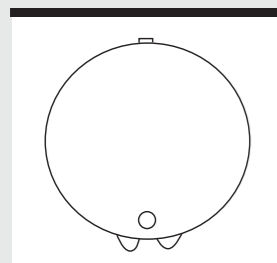

"Museum Für Kunst
und Gewerbe"
Hamburg 1986

LESTER 220

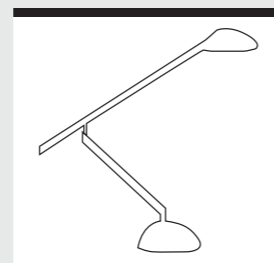

"Museum Für
Angewandte Kunst"
Köln 1990

"Design-Auswahl 1988"
Stuttgart

4461



Segnalazione
Compasso d'Oro,
Milano 1956

S154

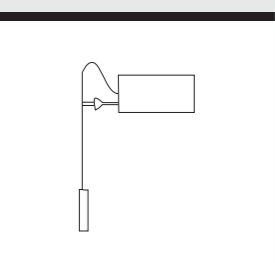

Segnalazione
Compasso d'Oro,
Milano 1955

LU-LU

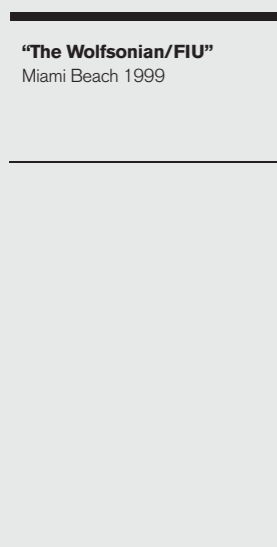

"The Wolfsonian/FIU"
Miami Beach 1999

SISTER 365

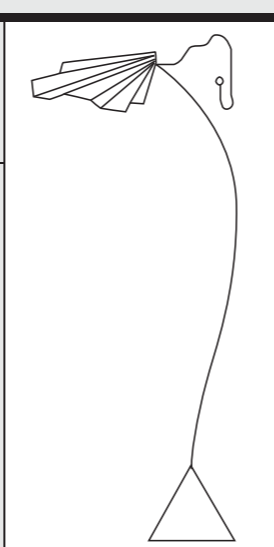

Selezione Compasso
d'Oro ADI
Milano 1991

COUPÈ 3321

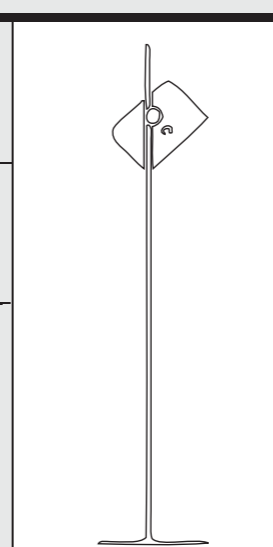

International Design Award
American Institute of
Interior Designers Chicago
1968

"Museum of Modern Art"
New York 1968,

Museum "Die Neue
Sammlung"
München 1983

LAMPPU

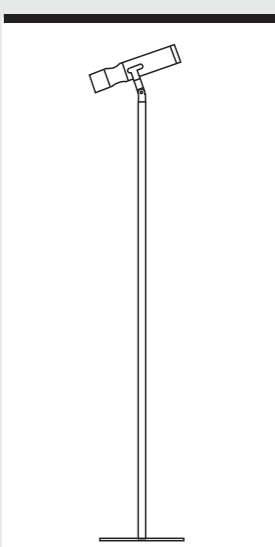

Selezione Compasso d'Oro
ADI
Milano 2004

I DESIGNERS OLUCE / OLUCE DESIGNERS**TITO AGNOLI****ANGELETTI & RUZZA****ANTONIA ASTORI E NICOLA DE PONTI****EMMANUEL BABLED****JÖRG BONER****FRANCESCA BORELLI****STEFANO CASCIANI****CARLO COLOMBO****JOE COLOMBO****NICOLA GALLIZIA****FERDI GIARDINI****GIOPATO&COOMBES****SAM HECHT****TOSHIYUKI KITA****MARTA LAUDANI & MARCO ROMANELLI****VICO MAGISTRETTI****MIST-O****NENDO****LUTZ PANKOW****MARIANA PELLEGRINO SOTO****CHRISTOPHE PILLET****FRANCESCO ROTA****STUDIO 63****VICTOR VASILEV****MARCO ZANUSO**

Graphic Design
GB studio

Fotografie / Photos
Adriano Brusaferrì
Gionata Xerra con Pierpaolo Mazzola
Alessandro Gaja
Studio Azzurro
Donato Di Bello
Andrea Basile
Federico Cedrone

Stylist
Studio Salaris

Coordinamento / Coordination
Franco Lettera
R + W

thanks to
Baxter
Francesca Verardo
Gorlan
Ilaria Marelli
Mani Ceramics
Niki Jones
Sans Tabù
Seambè
Texturae

O luce s.r.l.
Uffici commerciali e stabilimenti:
Via Brescia, 2 20097
San Donato Milanese - Milano
T. 02) 98 49 14 35 F. 02) 98 49 07 79
www.oluce.com info@oluce.com

Finito di stampare presso
Grafiche Milani - Segrate (MI)
febbraio 2018